

# COOKING EQUIPMENT GUIDE

## MANUFACTURERS & IMPORTERS OF QUALITY CATERING EQUIPMENT



*Fornetto*  
Deck Ovens



**MAESTRO-MIX**  
Mixers



**MITCHEL**  
REFRIGERATION  
Refrigeration



**ROYSTON**  
Rotisserie



**WOKSSS**  
Waterless Woks



**REEF & BEEF**  
BBQ Burners



*TITAN*  
Cool Room Shelving



**888**  
Stainless Steel Benching



**ROYSTON**  
Counterline

## 2010 CATALOGUE

It is the sales person's responsibility to make sure that the equipment is suitable for the users intent.  
Please Note: All care was taken while compiling this catalogue. Specifications and prices may change without notice, also the appearance of the products may change from time to time.



# TABLE OF CONTENTS



Stainless Steel	1
Cool Room Shelving	13
Planetary Mixers / Spiral Mixers	17
Bakery Equipment	22
Cooking Equipment	25
Ovens	29
Food Warming	33
Counterline / Food Preparation	35
Beverage	43
Ice Machine	44
Refrigeration	45
Account Application Form	53
Terms & Condition	54
Conditions of Sale	55

While all due care was taken when compiling this catalogue, appearance and specifications may change. Please confirm with the company prior to ordering, dimensions, energy requirements and pricing.





# Stainless Steel Overshelf Bench

STAINLESS STEEL

Model	Product Description	Unit Size / Shipping Size W x D x H (mm)	Weight
-------	---------------------	---	--------

	<b>888 00-1500L</b> <ul style="list-style-type: none"> <li>• 1500mm s/steel single tier overshelf</li> <li>• 1.2mm thick s/steel</li> <li>• 80mm s/steel round foot for fastening into bench tops</li> <li>• Quick and simple assembly</li> </ul>	Unit Size: 1500 x 300 x 450  Shipping Size: 1550 x 350 x 80	8.5 kg
---	---	---	--------

	<b>888 00-1800L</b> <ul style="list-style-type: none"> <li>• 1800mm s/steel single tier overshelf</li> <li>• 1.2mm thick s/steel</li> <li>• 80mm s/steel round foot for fastening into bench tops</li> <li>• Quick and simple assembly</li> </ul>	Unit Size: 1800 x 300 x 450  Shipping Size: 1850 x 350 x 80	10 kg
--	---	---	-------

	<b>888 01-1500L</b> <ul style="list-style-type: none"> <li>• 1500mm s/steel double tier overshelf</li> <li>• 1.2mm thick s/steel</li> <li>• 80mm s/steel round foot for fastening into bench tops</li> <li>• Adjustable middle shelf</li> <li>• Quick and simple assembly</li> </ul>	Unit Size: 1500 x 300 x 750  Shipping Size: 1550 x 350 x 90	14.5 kg
---	--	---	---------

	<b>888 01-1800L</b> <ul style="list-style-type: none"> <li>• 1800mm s/steel double tier overshelf</li> <li>• 1.2mm thick s/steel</li> <li>• 80mm s/steel round foot for fastening into bench tops</li> <li>• Adjustable middle shelf</li> <li>• Quick and simple assembly</li> </ul>	Unit Size: 1800 x 300 x 750  Shipping Size: 1850 x 350 x 90	17.5 kg
---	--	---	---------



# Stainless Steel Benches

Model	Product Description	Unit Size / Shipping Size W x D x H (mm)	Weight
-------	---------------------	---	--------

 <p>*Available with castors</p>	<p><b>888 02-1200L</b></p>	<ul style="list-style-type: none"> <li>• 1200mm s/steel bench + shelf under</li> <li>• 1.2mm thick s/steel</li> <li>• 760mm deep</li> <li>• Full stainless steel shelf (Not Galvanized)</li> <li>• Adjustable feet</li> <li>• 38mm diameter round s/steel legs, satin polished</li> <li>• 2mm steel reinforced backing</li> <li>• Flat packed for easy transport</li> <li>• Quick and simple assembly</li> </ul> <p><b>Note:</b> Standard height 900mm. If castors required, please confirm finished height at the time of the order. Castors are an optional extra.</p>	<p>Unit Size: 1200 x 760 x 900</p> <p>Shipping Size: 1250 x 810 x 150</p> <p>40 kg</p>
--	--------------------------------	--	--

 <p>*Available with castors</p>	<p><b>888 02-1500L</b></p>	<ul style="list-style-type: none"> <li>• 1500mm s/steel bench + shelf under</li> <li>• 1.2mm thick s/steel</li> <li>• 760mm deep</li> <li>• Full stainless steel shelf (Not Galvanized)</li> <li>• Adjustable feet</li> <li>• 38mm diameter round s/steel legs, satin polished</li> <li>• 2mm steel reinforced backing</li> <li>• Flat packed for easy transport</li> <li>• Quick and simple assembly</li> </ul> <p><b>Note:</b> Standard height 900mm. If castors required, please confirm finished height at the time of the order. Castors are an optional extra.</p>	<p>Unit Size: 1500 x 760 x 900</p> <p>Shipping Size: 1550 x 810 x 150</p> <p>50 kg</p>
---	--------------------------------	--	--

 <p>*Available with castors</p>	<p><b>888 02-1800L</b></p>	<ul style="list-style-type: none"> <li>• 1800mm s/steel bench + shelf under</li> <li>• 1.2mm thick s/steel</li> <li>• 760mm deep</li> <li>• Full stainless steel shelf (Not Galvanized)</li> <li>• Adjustable feet</li> <li>• 38mm diameter round s/steel legs, satin polished</li> <li>• 2mm steel reinforced backing</li> <li>• Flat packed for easy transport</li> <li>• Quick and simple assembly</li> </ul> <p><b>Note:</b> Standard height 900mm. If castors required, please confirm finished height at the time of the order. Castors are an optional extra.</p>	<p>Unit Size: 1800 x 760 x 900</p> <p>Shipping Size: 1850 x 810 x 150</p> <p>70 kg</p>
--	--------------------------------	--	--

 <p>*Available with castors</p>	<p><b>888 02-2400L</b></p>	<ul style="list-style-type: none"> <li>• 2400mm s/steel bench + shelf under</li> <li>• 1.2mm thick s/steel</li> <li>• 760mm deep</li> <li>• Full stainless steel shelf (Not Galvanized)</li> <li>• Adjustable feet</li> <li>• 38mm diameter round s/steel legs, satin polished</li> <li>• 2mm steel reinforced backing</li> <li>• Flat packed for easy transport</li> <li>• Quick and simple assembly</li> </ul> <p><b>Note:</b> Standard height 900mm. If castors required, please confirm finished height at the time of the order. Castors are an optional extra.</p>	<p>Unit Size: 2400 x 760 x 900</p> <p>Shipping Size: 2450 x 810 x 150</p> <p>90 kg</p>
--	--------------------------------	--	--

\*Castors available at an extra cost. Available with or without brakes.

STAINLESS STEEL 2



# Stainless Steel Benches

**STAINLESS STEEL**

Model	Product Description	Unit Size / Shipping Size W x D x H (mm)	Weight
-------	---------------------	---	--------

	<b>888 03-300L</b> <ul style="list-style-type: none"> <li>• 300mm s/steel bench + splashback + shelf under</li> <li>• 760mm deep</li> <li>• 1.2mm thick s/steel</li> <li>• Full stainless steel shelf (Not Galvanized)</li> <li>• Adjustable feet</li> <li>• 38mm diameter round s/steel legs, satin polished</li> <li>• 2mm steel reinforced backing</li> <li>• 90mm high splashback with bevelled edge</li> <li>• Flat packed for easy transport</li> <li>• Quick and simple assembly</li> </ul>	Unit Size: 300 x 760 x 900  Shipping Size: 350 x 810 x 250	13 kg
---	--	--	-------

	<b>888 03-450L</b> <ul style="list-style-type: none"> <li>• 450mm s/steel bench + splashback + shelf under</li> <li>• 760mm deep</li> <li>• 1.2mm thick s/steel</li> <li>• Full stainless steel shelf (Not Galvanized)</li> <li>• Adjustable feet</li> <li>• 38mm diameter round s/steel legs, satin polished</li> <li>• 2mm steel reinforced backing</li> <li>• 90mm high splashback with bevelled edge</li> <li>• Flat packed for easy transport</li> <li>• Quick and simple assembly</li> </ul>	Unit Size: 450 x 760 x 900  Shipping Size: 500 x 810 x 250	20 kg
--	--	--	-------

	<b>888 03-600L</b> <ul style="list-style-type: none"> <li>• 600mm s/steel bench + splashback + shelf under</li> <li>• 760mm deep</li> <li>• 1.2mm thick s/steel</li> <li>• Full stainless steel shelf (Not Galvanized)</li> <li>• Adjustable feet</li> <li>• 38mm diameter round s/steel legs, satin polished</li> <li>• 2mm steel reinforced backing</li> <li>• 90mm high splashback with bevelled edge</li> <li>• Flat packed for easy transport</li> <li>• Quick and simple assembly</li> </ul>	Unit Size: 600 x 760 x 900  Shipping Size: 650 x 810 x 250	25 kg
---	--	--	-------

	<b>888 03-1200L</b> <ul style="list-style-type: none"> <li>• 1200mm s/steel bench + splashback + shelf under</li> <li>• 760mm deep</li> <li>• 1.2mm thick s/steel</li> <li>• Full stainless steel shelf (Not Galvanized)</li> <li>• Adjustable feet</li> <li>• 38mm diameter round s/steel legs, satin polished</li> <li>• 2mm steel reinforced backing</li> <li>• 90mm high splashback with bevelled edge</li> <li>• Flat packed for easy transport</li> <li>• Quick and simple assembly</li> </ul>	Unit Size: 1200 x 760 x 900  Shipping Size: 1250 x 810 x 250	50 kg
---	--	--	-------



# Stainless Steel Benches

Model	Product Description	Unit Size / Shipping Size W x D x H (mm)	Weight
-------	---------------------	---	--------

	<p><b>888 03-1500L</b></p>	<ul style="list-style-type: none"> <li>• 1500mm s/steel bench + splashback + shelf under</li> <li>• 760mm deep</li> <li>• 1.2mm thick s/steel</li> <li>• Full stainless steel shelf (Not Galvanized)</li> <li>• Adjustable feet</li> <li>• 38mm diameter round s/steel legs, satin polished</li> <li>• 2mm steel reinforced backing</li> <li>• 90mm high splashback with bevelled edge</li> <li>• Flat packed for easy transport</li> <li>• Quick and simple assembly</li> </ul>	<p>Unit Size: 1500 x 760 x 900</p> <p>Shipping Size: 1550 x 810 x 250</p>	<p>65 kg</p>
---	--------------------------------	--	---	--------------

	<p><b>888 03-1800L</b></p>	<ul style="list-style-type: none"> <li>• 1800mm s/steel bench + splashback + shelf under</li> <li>• 760mm deep</li> <li>• 1.2mm thick s/steel</li> <li>• Full stainless steel shelf (Not Galvanized)</li> <li>• Adjustable feet</li> <li>• 38mm diameter round s/steel legs, satin polished</li> <li>• 2mm steel reinforced backing</li> <li>• 90mm high splashback with bevelled edge</li> <li>• Flat packed for easy transport</li> <li>• Quick and simple assembly</li> </ul>	<p>Unit Size: 1800 x 760 x 900</p> <p>Shipping Size: 1850 x 810 x 250</p>	<p>85 kg</p>
--	--------------------------------	--	---	--------------

	<p><b>888 05-900L</b></p>	<ul style="list-style-type: none"> <li>• Corner bench + splashback</li> <li>• 760mm deep</li> <li>• 1.2mm thick s/steel</li> <li>• Full stainless steel shelf (Not Galvanized)</li> <li>• Adjustable feet</li> <li>• 38mm diameter round s/steel legs, satin polished</li> <li>• 2mm steel reinforced backing</li> <li>• 120mm high splashback with bevelled edge</li> <li>• Flat packed for easy transport</li> <li>• Quick and simple assembly</li> </ul> <p style="text-align: center;"><b>MADE TO ORDER</b></p>	<p>Unit Size: 900 (x2) x 760 x 900</p> <p>Shipping Size: 950 x 950 x 250</p>	<p>65 kg</p>
---	-------------------------------	---	--	--------------

**STAINLESS STEEL**





# Stainless Steel Sink Benches

**STAINLESS STEEL**

Model	Product Description	Unit Size / Shipping Size W x D x H (mm)	Weight
-------	---------------------	---	--------

	<p><b>888 06-1200L</b></p>	<ul style="list-style-type: none"> <li>• 1200mm s/steel single sink bowl with splashback and tube pot rack under</li> <li>• 2mm steel reinforced backing</li> <li>• 120mm high splashback with bevelled edge</li> <li>• Bowl size: 450 x 450 x 250 deep</li> <li>• 50mm waste hole</li> <li>• Satin polish s/steel tube pot rack under</li> <li>• Central sink</li> <li>• 38mm diameter round s/steel legs, satin polished</li> <li>• Adjustable feet</li> <li>• Flat packed for easy transport</li> <li>• Quick and simple assembly</li> </ul>	<p>Unit Size: 1200 x 760 x 900</p> <p>Shipping Size: 1250 x 810 x 450</p> <p>30 kg</p>
---	--------------------------------	---	--



	<p><b>888 06-1500L</b></p>	<ul style="list-style-type: none"> <li>• 1500mm s/steel single sink bowl with splashback and tube pot rack under</li> <li>• 2mm steel reinforced backing</li> <li>• 120mm high splashback with bevelled edge</li> <li>• Bowl size: 450 x 450 x 250 deep</li> <li>• 50mm waste hole</li> <li>• Satin polish s/steel tube pot rack under</li> <li>• Central sink</li> <li>• 38mm diameter round s/steel legs, satin polished</li> <li>• Adjustable feet</li> <li>• Flat packed for easy transport</li> <li>• Quick and simple assembly</li> </ul>	<p>Unit Size: 1500 x 760 x 900</p> <p>Shipping Size: 1550 x 810 x 900</p> <p>35 kg</p>
--	--------------------------------	---	--

	<p><b>888 06-1800L</b></p>	<ul style="list-style-type: none"> <li>• 1800mm s/steel single sink bowl with splashback and tube pot rack under</li> <li>• 2mm steel reinforced backing</li> <li>• 120mm high splashback with bevelled edge</li> <li>• Bowl size: 450 x 450 x 250 deep</li> <li>• 50mm waste hole</li> <li>• Satin polish s/steel tube pot rack under</li> <li>• Central sink</li> <li>• 38mm diameter round s/steel legs, satin polished</li> <li>• Adjustable feet</li> <li>• Flat packed for easy transport</li> <li>• Quick and simple assembly</li> </ul>	<p>Unit Size: 1800 x 760 x 900</p> <p>Shipping Size: 1850 x 810 x 450</p> <p>45 kg</p>
---	--------------------------------	---	--



# Stainless Steel Sink Benches

Model	Product Description	Unit Size / Shipping Size W x D x H (mm)	Weight
-------	---------------------	---	--------

	<p><b>888 07-1500L</b></p>	<ul style="list-style-type: none"> <li>• 1500mm s/steel double sink bench with splashback and tube pot rack under</li> <li>• 120mm high splashback with bevelled edge</li> <li>• 1.2mm thick s/steel</li> <li>• 2mm steel reinforced backing</li> <li>• Adjustable feet</li> <li>• 38mm diameter round s/steel legs, satin polished</li> <li>• Bowl sizes: 450 x 450 x 250 deep</li> <li>• 50mm waste hole</li> <li>• Satin polish s/steel tube pot rack under</li> <li>• Central sink</li> <li>• Flat packed for easy transport</li> <li>• Quick and simple assembly</li> </ul>	<p>Unit Size: 1500 x 760 x 900</p> <p>Shipping Size: 1550 x 810 x 450</p>	<p>38 kg</p>
	<p><b>888 07-1800L</b></p>	<ul style="list-style-type: none"> <li>• 1800mm s/steel double sink bench with splashback and tube pot rack under</li> <li>• 120mm high splashback with bevelled edge</li> <li>• 1.2mm thick s/steel</li> <li>• 2mm steel reinforced backing</li> <li>• Adjustable feet</li> <li>• 38mm diameter round s/steel legs, satin polished</li> <li>• Bowl sizes: 450 x 450 x 250 deep</li> <li>• 50mm waste hole</li> <li>• Satin polish s/steel tube pot rack under</li> <li>• Central sink</li> <li>• Flat packed for easy transport</li> <li>• Quick and simple assembly</li> </ul>	<p>Unit Size: 1800 x 760 x 900</p> <p>Shipping Size: 1850 x 810 x 450</p>	<p>45 kg</p>
	<p><b>888 07-2400L</b></p>	<ul style="list-style-type: none"> <li>• 2400mm s/steel double sink bench with splashback and tube pot rack under</li> <li>• 120mm high splashback with bevelled edge</li> <li>• 1.2mm thick s/steel</li> <li>• 2mm steel reinforced backing</li> <li>• Adjustable feet</li> <li>• 38mm diameter round s/steel legs, satin polished</li> <li>• Bowl sizes: 450 x 450 x 250 deep</li> <li>• 50mm waste hole</li> <li>• Satin polish s/steel tube pot rack under</li> <li>• Central sink</li> <li>• Flat packed for easy transport</li> <li>• Quick and simple assembly</li> </ul>	<p>Unit Size: 2400 x 760 x 900</p> <p>Shipping Size: 2450 x 810 x 900</p>	<p>52 kg</p>

**STAINLESS STEEL**  
6





# Stainless Steel Wall Shelf

**STAINLESS STEEL**

Model	Product Description	Unit Size / Shipping Size W x D x H (mm)	Weight
-------	---------------------	---	--------

	<b>888 08-1200L</b>	<ul style="list-style-type: none"> <li>• 1200mm s/steel solid wall shelf with brackets</li> <li>• 1.2mm thick s/steel bracket</li> <li>• Quick and simple assembly</li> </ul>	Unit Size: 1200 x 300 x 250  Shipping Size: 1250 x 350 x 120	6 kg
---	-------------------------	---	--	------

	<b>888 08-1500L</b>	<ul style="list-style-type: none"> <li>• 1500mm s/steel solid wall shelf with brackets</li> <li>• 1.2mm thick s/steel bracket</li> <li>• Quick and simple assembly</li> </ul>	Unit Size: 1500 x 300 x 250  Shipping Size: 1550 x 350 x 120	7 kg
--	-------------------------	---	--	------

	<b>888 08-1800L</b>	<ul style="list-style-type: none"> <li>• 1800mm s/steel solid wall shelf with brackets</li> <li>• 1.2mm thick s/steel bracket</li> <li>• Quick and simple assembly</li> </ul>	Unit Size: 1800 x 300 x 250  Shipping Size: 1850 x 350 x 120	8 kg
---	-------------------------	---	--	------

 <p>Note: Middle bracket centered exactly</p>	<b>888 08-2400L</b>	<ul style="list-style-type: none"> <li>• 2400mm s/steel solid wall shelf with brackets</li> <li>• 1.2mm thick s/steel bracket</li> <li>• Quick and simple assembly</li> </ul>	Unit Size: 2400 x 300 x 250  Shipping Size: 2450 x 350 x 120	9 kg
--	-------------------------	---	--	------





# Stainless Steel Pipe Wall Shelf

Model	Product Description	Unit Size / Shipping Size W x D x H (mm)	Weight
-------	---------------------	---	--------

	<b>888</b> <b>11-1200L</b>	<ul style="list-style-type: none"> <li>• 1200mm s/steel pipe wall shelf with brackets</li> <li>• 25mm diameter round s/steel pipes with welded end caps (no food traps)</li> <li>• Quick and simple assembly</li> </ul>	Unit Size: 1200 x 300 x 250  Shipping Size: 1250 x 350 x 120	5 kg
---	-------------------------------	---	--	------

	<b>888</b> <b>11-1500L</b>	<ul style="list-style-type: none"> <li>• 1500mm s/steel pipe wall shelf with brackets</li> <li>• 25mm diameter round s/steel pipes with welded end caps (no food traps)</li> <li>• Quick and simple assembly</li> </ul>	Unit Size: 1500 x 300 x 250  Shipping Size: 1550 x 350 x 120	5.5 kg
--	-------------------------------	---	--	--------

	<b>888</b> <b>11-1800L</b>	<ul style="list-style-type: none"> <li>• 1800mm s/steel pipe wall shelf with brackets</li> <li>• 25mm diameter round s/steel pipes with welded end caps (no food traps)</li> <li>• Quick and simple assembly</li> </ul>	Unit Size: 1800 x 300 x 250  Shipping Size: 1850 x 350 x 120	6 kg
---	-------------------------------	---	--	------

 <p>Note: Middle bracket centred exactly</p>	<b>888</b> <b>11-2400L</b>	<ul style="list-style-type: none"> <li>• 2400mm s/steel pipe wall shelf with brackets</li> <li>• 25mm diameter round s/steel pipes with welded end caps (no food traps)</li> <li>• Quick and simple assembly</li> </ul>	Unit Size: 2400 x 300 x 250  Shipping Size: 2450 x 350 x 120	6.5 kg
---	-------------------------------	---	--	--------

**STAINLESS STEEL**





# Stainless Steel Sink / Benches

STAINLESS STEEL<sup>®</sup>

Model	Product Description	Unit Size / Shipping Size W x D x H (mm)	Weight
-------	---------------------	--	--------

	<p><b>888 12-L D/W OUTLET BENCH LEFT OF THE DISHWASHER</b></p>	<ul style="list-style-type: none"> <li>• 750mm outlet bench - LHS of dishwasher</li> <li>• 1.2mm thick s/steel</li> <li>• Full stainless steel shelf (Not Galvanized)</li> <li>• 38mm diameter round s/steel legs</li> <li>• 2mm steel reinforced backing</li> <li>• Bench will hook into most commercial dishwashers to avoid water spilling out during washing process</li> <li>• 120mm high splashback with bevelled edge</li> <li>• Adjustable feet</li> <li>• Quick and simple assembly</li> </ul>	<p>Unit Size: 750 x 760 x 900</p> <p>Shipping Size: 800 x 810 x 200</p>	40 kg
---	--	---	---	-------

	<p><b>888 12-R D/W OUTLET BENCH RIGHT OF THE DISHWASHER</b></p>	<ul style="list-style-type: none"> <li>• 750mm outlet bench - RHS of dishwasher</li> <li>• 1.2mm thick s/steel</li> <li>• Full stainless steel shelf (Not Galvanized)</li> <li>• 38mm diameter round s/steel legs</li> <li>• 2mm steel reinforced backing</li> <li>• Bench will hook into most commercial dishwashers to avoid water spilling out during washing process</li> <li>• 120mm high splashback with bevelled edge</li> <li>• Adjustable feet</li> <li>• Quick and simple assembly</li> </ul>	<p>Unit Size: 750 x 760 x 900</p> <p>Shipping Size: 800 x 810 x 200</p>	40 kg
--	---	---	---	-------

	<p><b>888 13-L D/W INLET LEFT OF THE DISHWASHER</b></p>	<ul style="list-style-type: none"> <li>• 1500mm inlet bench with double sink bowl - LHS of dishwasher</li> <li>• 1.2mm thick s/steel</li> <li>• Full stainless steel shelf (Not Galvanized)</li> <li>• 38mm diameter round s/steel legs, satin polished</li> <li>• 2mm steel reinforced backing</li> <li>• Bench will hook into most commercial dishwashers to avoid water spilling out during washing process</li> <li>• 120mm high splashback with bevelled edge</li> <li>• Adjustable feet</li> <li>• Quick and simple assembly</li> </ul>	<p>Unit Size: 1500 x 760 x 900</p> <p>Shipping Size: 1550 x 810 x 250</p>	70 kg
---	---	---	---	-------

	<p><b>888 13-R D/W INLET RIGHT OF THE DISHWASHER</b></p>	<ul style="list-style-type: none"> <li>• 1500mm inlet bench with double sink bowl - RHS of dishwasher</li> <li>• 1.2mm thick s/steel</li> <li>• Full stainless steel shelf (Not Galvanized)</li> <li>• 38mm diameter round s/steel legs, satin polished</li> <li>• 2mm steel reinforced backing</li> <li>• Bench will hook into most commercial dishwashers to avoid water spilling out during washing process</li> <li>• 120mm high splashback with bevelled edge</li> <li>• Adjustable feet</li> <li>• Quick and simple assembly</li> </ul>	<p>Unit Size: 1500 x 760 x 900</p> <p>Shipping Size: 1550 x 810 x 250</p>	70 kg
---	--	---	---	-------





# Stainless Steel

Model	Product Description	Unit Size / Shipping Size W x D x H (mm)	Weight
-------	---------------------	---	--------

	<p><b>888 12-D/W BASK</b></p>	<ul style="list-style-type: none"> <li>• Flat pack dishwasher rack basket</li> <li>• Holds 3 baskets with dimensions of 500 x 500 x 100 and 1 tray</li> <li>• Full s/steel construction</li> <li>• Adjustable feet</li> <li>• Flat packed</li> <li>• Quick and simple assembly</li> </ul>	<p>Unit Size: 560 x 560 x 620</p> <p>Shipping Size: 560 x 560 x 100</p>	<p>10 kg</p>
---	---------------------------------------	---	---	--------------

	<p><b>888 10-S/S DRAW</b></p>	<ul style="list-style-type: none"> <li>• S/steel draw inside flange</li> <li>• Drawers to suit s/steel bench</li> </ul>	<p>Unit Size: 440 x 460 x 155</p>	
--	-----------------------------------	---	---------------------------------------	--

	<p><b>888 14 - 2T</b></p>	<ul style="list-style-type: none"> <li>• Quality s/steel 2 tier trolley with castors</li> <li>• Full s/steel construction</li> <li>• 25mm square tubed s/steel frame for extra strength</li> <li>• 100mm lockable castors</li> <li>• Silent running wheels</li> <li>• Tray size 450 x 800 mm</li> <li>• Pressed shelves for easy cleaning</li> <li>• Flat packed for easy transport</li> <li>• Quick and simple assembly</li> </ul>	<p>Unit Size: 850 x 450 x 900</p> <p>Shipping Size: 900 x 500 x 160</p>	<p>22 kg</p>
---	-------------------------------	---	---	--------------

	<p><b>888 15 - 3T</b></p>	<ul style="list-style-type: none"> <li>• Quality s/steel 3 tier trolley with castors</li> <li>• Full s/steel construction</li> <li>• 25mm square tubed s/steel frame for extra strength</li> <li>• 100mm lockable castors</li> <li>• Silent running wheels</li> <li>• Tray size 450 x 800 mm</li> <li>• Pressed shelves for easy cleaning</li> <li>• Flat packed for easy transport</li> <li>• Quick and simple assembly</li> </ul>	<p>Unit Size: 850 x 450 x 900</p> <p>Shipping Size: 900 x 500 x 160</p>	<p>29 kg</p>
---	-------------------------------	---	---	--------------

**STAINLESS STEEL**





# Stainless Steel

**STAINLESS STEEL**

Model	Product Description	Unit Size / Shipping Size W x D x H (mm)	Weight
-------	---------------------	---	--------

	<p><b>888</b> <b>18-BAK-10</b></p> <ul style="list-style-type: none"> <li>• Quality s/steel mobile bakery rack trolley</li> <li>• <u>Holds 10 trays</u></li> <li>• Suits 18" x 29" bakery tray</li> <li>• 25mm square tubed s/steel frame for extra strength</li> <li>• Electrostaticly polished</li> <li>• 100mm high quality castors               <ul style="list-style-type: none"> <li>- Non marking</li> <li>- 2 lockable</li> </ul> </li> <li>• Tray lock both sides for safe moving</li> <li>• Flat packed for easy transport</li> <li>• Quick and simple assembly</li> </ul>	<p>Unit Size: 525 x 750 x 1860</p> <p>Shipping Size: 100 x 790 x 1800</p>	27 kg
---	---	---	-------

	<p><b>888</b> <b>18-BAK-15</b></p> <ul style="list-style-type: none"> <li>• Quality s/steel mobile bakery rack trolley</li> <li>• <u>Holds 15 trays</u></li> <li>• Suits 18" x 29" bakery tray</li> <li>• 25mm square tubed s/steel frame for extra strength</li> <li>• Electrostaticly polished</li> <li>• 100mm high quality castors               <ul style="list-style-type: none"> <li>- Non marking</li> <li>- 2 lockable</li> </ul> </li> <li>• Tray lock both sides for safe moving</li> <li>• Flat packed for easy transport</li> <li>• Quick and simple assembly</li> </ul>	<p>Unit Size: 525 x 750 x 1860</p> <p>Shipping Size: 100 x 790 x 1800</p>	30 kg
--	---	---	-------

	<p><b>888</b> <b>16-BAK-10</b></p> <ul style="list-style-type: none"> <li>• Quality s/steel mobile bakery rack trolley</li> <li>• <u>Holds 10 trays</u></li> <li>• Suits 16" x 29" bakery tray</li> <li>• 25mm square tubed s/steel frame for extra strength</li> <li>• Electrostaticly polished</li> <li>• 100mm high quality castors               <ul style="list-style-type: none"> <li>- Non marking</li> <li>- 2 lockable</li> </ul> </li> <li>• Tray lock both sides for safe moving</li> <li>• Flat packed for easy transport</li> <li>• Quick and simple assembly</li> </ul>	<p>Unit Size: 465 x 750 x 1860</p> <p>Shipping Size: 100 x 790 x 1800</p>	27 kg
---	---	---	-------

	<p><b>888</b> <b>16-BAK-15</b></p> <ul style="list-style-type: none"> <li>• Quality s/steel mobile bakery rack trolley</li> <li>• <u>Holds 15 trays</u></li> <li>• Suits 16" x 29" bakery tray</li> <li>• 25mm square tubed s/steel frame for extra strength</li> <li>• Electrostaticly polished</li> <li>• 100mm high quality castors               <ul style="list-style-type: none"> <li>- Non marking</li> <li>- 2 lockable</li> </ul> </li> <li>• Tray lock both sides for safe moving</li> <li>• Flat packed for easy transport</li> <li>• Quick and simple assembly</li> </ul>	<p>Unit Size: 465 x 750 x 1860</p> <p>Shipping Size: 100 x 790 x 1800</p>	30 kg
---	---	---	-------



# Stainless Steel

Model	Product Description	Unit Size / Shipping Size W x D x H (mm)	Weight
-------	---------------------	---	--------

	<p><b>888 16 - GNM</b></p>	<ul style="list-style-type: none"> <li>• Quality mobile s/steel gastronorm trolley</li> <li>• <u>Holds 32 x 1/1 GN trays or 16 x 2/1 GN trays</u></li> <li>• 25mm square tubed s/steel frame for extra strength</li> <li>• Each shelf accomodates 2 gastronorm tray (1/1) 65mm deep</li> <li>• 120mm lockable castors</li> <li>• Tray lock both sides for safe moving</li> <li>• Flat packed for easy transport</li> <li>• Quick and simple assembly</li> </ul>	<p>Unit Size: 600 x 690 x 1735</p> <p>Shipping Size: 100 x 740 x 1700</p>	<p>33 kg</p>
---	--------------------------------	---	---	--------------

	<p><b>888 17 - GNM</b></p>	<ul style="list-style-type: none"> <li>• Quality mobile s/steel gastronorm trolley</li> <li>• <u>Holds 16 x 1/1 GN trays</u></li> <li>• 25mm square tubed s/steel frame for extra strength</li> <li>• 120mm lockable castors</li> <li>• Tray lock both sides for safe moving</li> <li>• Flat packed for easy transport</li> <li>• Quick and simple assembly</li> </ul>	<p>Unit Size: 415 x 620 x 1735</p> <p>Shipping Size: 100 x 680 x 1700</p>	<p>30 kg</p>
--	--------------------------------	--	---	--------------

 <p>without brakes</p> <p>with brakes</p>	<p><b>888 BENCH CAS</b></p> <p><b>BENCH CAS / BRAKE</b></p>	<ul style="list-style-type: none"> <li>• Castors to suit 888 benches</li> <li>• Castors with brakes to suit 888 benches</li> </ul>		
--	---	--	--	--

**STAINLESS STEEL**

# TITAN Cool Room / Dry Store Shelving Units

Model	Product Description	Unit Size / Shipping Size W x D x H (mm)	Weight
-------	---------------------	--	--------

	<b>TITAN C/R SHELIVING</b> <b>610 x 355</b>	<ul style="list-style-type: none"> <li>Cool room shelving</li> <li>Galvanized first and then grey powder coated</li> <li>Contains 4 shelves with 4 post and shelf clips</li> </ul>	Unit Size: 610 x 355 x 1825 <small>Pack of 4 Poles: 33 x 115 x 1825</small>	11.5 kg
	<b>TITAN C/R SHELIVING</b> <b>760 x 355</b>	<ul style="list-style-type: none"> <li>Adjustable feet</li> <li>Flat packed for easy transport</li> <li>Quick and simple assembly</li> </ul>	Unit Size: 760 x 355 x 1825 <small>Pack of 4 Poles: 33 x 115 x 1825</small>	12.2 kg
	<b>TITAN C/R SHELIVING</b> <b>910 x 355</b>		Unit Size: 910 x 355 x 1825 <small>Pack of 4 Poles: 33 x 115 x 1825</small>	13.5 kg
	<b>TITAN C/R SHELIVING</b> <b>1060 x 355</b>		Unit Size: 1060 x 355 x 1825 <small>Pack of 4 Poles: 33 x 115 x 1825</small>	15 kg
	<b>TITAN C/R SHELIVING</b> <b>1220 x 355</b>		Unit Size: 1220 x 355 x 1825 <small>Pack of 4 Poles: 33 x 115 x 1825</small>	16.6 kg
	<b>TITAN C/R SHELIVING</b> <b>1370 x 355</b>		Unit Size: 1370 x 355 x 1825 <small>Pack of 4 Poles: 33 x 115 x 1825</small>	22 kg
	<b>TITAN C/R SHELIVING</b> <b>1525 x 355</b>		Unit Size: 1525 x 355 x 1825 <small>Pack of 4 Poles: 33 x 115 x 1825</small>	24 kg
	<b>TITAN C/R SHELIVING</b> <b>1825 x 355</b>		Unit Size: 1825 x 355 x 1825 <small>Pack of 4 Poles: 33 x 115 x 1825</small>	29 kg

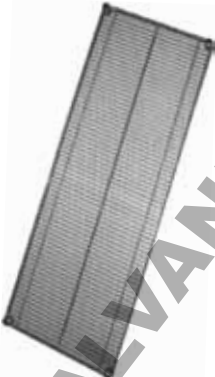
	<b>TITAN C/R WIRE SHELF</b> <b>610 x 355</b>	<ul style="list-style-type: none"> <li>Cool room shelving</li> <li>Galvanized first and then grey powder coated</li> <li>Single shelf</li> </ul>	Unit Size: 610 x 355 x 30	
	<b>TITAN C/R WIRE SHELF</b> <b>760 x 355</b>		Unit Size: 760 x 355 x 30	
	<b>TITAN C/R WIRE SHELF</b> <b>910 x 355</b>		Unit Size: 910 x 355 x 30	
	<b>TITAN C/R WIRE SHELF</b> <b>1060 x 355</b>		Unit Size: 1060 x 355 x 30	
	<b>TITAN C/R WIRE SHELF</b> <b>1220 x 355</b>		Unit Size: 1220 x 355 x 30	
	<b>TITAN C/R WIRE SHELF</b> <b>1370 x 355</b>		Unit Size: 1370 x 355 x 30	
	<b>TITAN C/R WIRE SHELF</b> <b>1525 x 355</b>		Unit Size: 1525 x 355 x 30	
	<b>TITAN C/R WIRE SHELF</b> <b>1825 x 355</b>		Unit Size: 1825 x 355 x 30	

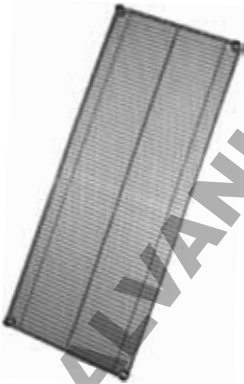
Model	Product Description	Unit Size / Shipping Size W x D x H (mm)	Weight
	<b>TITAN C/R SHELVING 610 x 455</b> <ul style="list-style-type: none"> <li>Cool room shelving</li> <li>Galvanized first and then grey powder coated</li> <li>Contains 4 shelves with 4 post and shelf clips</li> </ul>	Unit Size: 610 x 455 x 1825 Pack of 4 Poles: 33 x 115 x 1825	11.3 kg
	<b>TITAN C/R SHELVING 760 x 455</b> <ul style="list-style-type: none"> <li>Adjustable feet</li> <li>Flat packed for easy transport</li> <li>Quick and simple assembly</li> </ul>	Unit Size: 760 x 455 x 1825 Pack of 4 Poles: 33 x 115 x 1825	13 kg
	<b>TITAN C/R SHELVING 910 x 455</b>	Unit Size: 910 x 455 x 1825 Pack of 4 Poles: 33 x 115 x 1825	16 kg
	<b>TITAN C/R SHELVING 1060 x 455</b>	Unit Size: 1060 x 455 x 1825 Pack of 4 Poles: 33 x 115 x 1825	18.5 kg
	<b>TITAN C/R SHELVING 1220 x 455</b>	Unit Size: 1220 x 455 x 1825 Pack of 4 Poles: 33 x 115 x 1825	21.6 kg
	<b>TITAN C/R SHELVING 1370 x 455</b>	Unit Size: 1370 x 455 x 1825 Pack of 4 Poles: 33 x 115 x 1825	22.2 kg
	<b>TITAN C/R SHELVING 1525 x 455</b>	Unit Size: 1525 x 455 x 1825 Pack of 4 Poles: 33 x 115 x 1825	28.4 kg
	<b>TITAN C/R WIRE SHELF 610 x 455</b> <ul style="list-style-type: none"> <li>Cool room shelving</li> <li>Galvanized first and then grey powder coated</li> <li>Single shelf</li> </ul>	Unit Size: 610 x 455 x 30	
	<b>TITAN C/R WIRE SHELF 760 x 455</b>	Unit Size: 760 x 455 x 30	
	<b>TITAN C/R WIRE SHELF 910 x 455</b>	Unit Size: 910 x 455 x 30	
	<b>TITAN C/R WIRE SHELF 1060 x 455</b>	Unit Size: 1060 x 455 x 30	
	<b>TITAN C/R WIRE SHELF 1220 x 455</b>	Unit Size: 1220 x 455 x 30	
	<b>TITAN C/R WIRE SHELF 1370 x 455</b>	Unit Size: 1370 x 455 x 30	
	<b>TITAN C/R WIRE SHELF 1525 x 455</b>	Unit Size: 1525 x 455 x 30	
<b>TITAN C/R WIRE SHELF 1825 x 455</b>	Unit Size: 1825 x 455 x 30		

# TITAN Cool Room / Dry Store Shelving Units

Model	Product Description	Unit Size / Shipping Size W x D x H (mm)	Weight
-------	---------------------	--	--------

	<b>TITAN C/R SHELVING 610 x 610</b>	<ul style="list-style-type: none"> <li>Cool room shelving</li> <li>Galvanized first and then grey powder coated</li> <li>Contains 4 shelves with 4 post and shelf clips</li> </ul>	Unit Size: 610 x 610 x 1825 <small>Pack of 4 Poles: 33 x 115 x 1825</small>	14 kg
	<b>TITAN C/R SHELVING 760 x 610</b>	<ul style="list-style-type: none"> <li>Adjustable feet</li> <li>Flat packed for easy transport</li> <li>Quick and simple assembly</li> </ul>	Unit Size: 760 x 610 x 1825 <small>Pack of 4 Poles: 33 x 115 x 1825</small>	16 kg
	<b>TITAN C/R SHELVING 910 x 610</b>		Unit Size: 910 x 610 x 1825 <small>Pack of 4 Poles: 33 x 115 x 1825</small>	20.4 kg
	<b>TITAN C/R SHELVING 1060 x 610</b>		Unit Size: 1060 x 610 x 1825 <small>Pack of 4 Poles: 33 x 115 x 1825</small>	24.8 kg
	<b>TITAN C/R SHELVING 1220 x 610</b>		Unit Size: 1220 x 610 x 1825 <small>Pack of 4 Poles: 33 x 115 x 1825</small>	29 kg
	<b>TITAN C/R SHELVING 1370 x 610</b>		Unit Size: 1370 x 610 x 1825 <small>Pack of 4 Poles: 33 x 115 x 1825</small>	32.8 kg
	<b>TITAN C/R SHELVING 1525 x 610</b>		Unit Size: 1525 x 610 x 1825 <small>Pack of 4 Poles: 33 x 115 x 1825</small>	35.4 kg
	<b>TITAN C/R SHELVING 1825 x 610</b>		Unit Size: 1825 x 610 x 1825 <small>Pack of 4 Poles: 33 x 115 x 1825</small>	43.6 kg

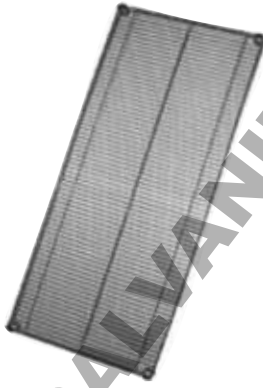
	<b>TITAN C/R WIRE SHELF 610 x 610</b>	<ul style="list-style-type: none"> <li>Cool room shelving</li> <li>Galvanized first and then grey powder coated</li> <li>Single shelf</li> </ul>	Unit Size: 610 x 610 x 30	
	<b>TITAN C/R WIRE SHELF 760 x 610</b>		Unit Size: 760 x 610 x 30	
	<b>TITAN C/R WIRE SHELF 910 x 610</b>		Unit Size: 910 x 610 x 30	
	<b>TITAN C/R WIRE SHELF 1060 x 610</b>		Unit Size: 1060 x 610 x 30	
	<b>TITAN C/R WIRE SHELF 1220 x 610</b>		Unit Size: 1220 x 610 x 30	
	<b>TITAN C/R WIRE SHELF 1370 x 610</b>		Unit Size: 1370 x 610 x 30	
	<b>TITAN C/R WIRE SHELF 1525 x 610</b>		Unit Size: 1525 x 610 x 30	
	<b>TITAN C/R WIRE SHELF 1825 x 610</b>		Unit Size: 1825 x 610 x 30	

# TITAN Cool Room Shelving

Model	Product Description	Unit Size / Shipping Size W x D x H (mm)	Weight
-------	---------------------	---	--------

	<b>TITAN HOOK FOR CORNER UNIT</b>	<ul style="list-style-type: none"> <li>• Hook for shelving for corner postless assembly</li> </ul>	Unit Size: 15 x 25 x 25	14 gms
---	-----------------------------------	--	----------------------------	--------

	<b>TITAN POST</b>	<ul style="list-style-type: none"> <li>• Post with bolt foot - for standard installation</li> </ul>	Unit Size: 30 x 30 x 1825  Shipping Size: 110 x 30 x 1910	1.45 kg
--	-------------------	---	---	---------

 <p>without brakes</p> <p>with brakes</p>	<b>TITAN CAS-SET</b>  <b>TITAN CAS</b>  <b>TITAN CAS / BRAKE</b>	<ul style="list-style-type: none"> <li>• 125mm diameter castors</li> <li>• Pack of 4: 2 with brakes and 2 without brakes</li> <li>• Castors without brakes</li> <li>• Castors with brakes</li> <li>• Not recommended for narrow units</li> </ul> <p><b>WARNING:</b> Castors are not recommended for narrow units</p>	Unit Size: (2x) 40 x 100 x 180 (2x) 50 x 100 x 180  40 x 100 x 180  50 x 100 x 180	2.9 kg  0.70 kg  0.70 kg
--	--	--	--	--------------------------------------

Model	Product Description	Unit Size / Shipping Size W x D x H (mm)	Weight
-------	---------------------	--	--------

 <p>New Model</p>	<b>Maestro Mix B10GFA</b> <ul style="list-style-type: none"> <li>• 10 litre planetary mixer</li> <li>• 3 speed gearbox</li> <li>• Beater, whisk &amp; dough hook attachments</li> <li>• Lowering arm safety switch</li> <li>• Missing bowl safety switch</li> <li>• Gear driven</li> <li>• Safety guard incorporating safety switch</li> <li>• External overload reset</li> <li>• 240volts 10amps</li> </ul>	Unit Size: 470 x 450 x 600  Shipping Size: 550 x 485 x 730	58 kg
--	--	--	-------

 <p>New Model</p>	<b>Maestro Mix B20GA</b> <ul style="list-style-type: none"> <li>• 20 litre planetary mixer</li> <li>• 3 speed gearbox</li> <li>• Beater, whisk &amp; dough hook attachments</li> <li>• Lowering arm safety switch</li> <li>• Missing bowl safety switch</li> <li>• Gear driven</li> <li>• Safety guard incorporating safety switch</li> <li>• External overload reset</li> <li>• 240volts 10amps</li> </ul>	Unit Size: 420 x 500 x 760  Shipping Size: 630 x 630 x 910	110 kg
---	---	--	--------

	<b>Maestro Mix B30C</b> <ul style="list-style-type: none"> <li>• 30 litre planetary mixer</li> <li>• 3 speed gearbox</li> <li>• Beater, whisk &amp; dough hook attachments</li> <li>• Lowering arm safety switch</li> <li>• Gear driven</li> <li>• Safety guard incorporating safety switch</li> <li>• External overload reset</li> <li>• 240volts 15amps</li> </ul>	Unit Size: 530 x 550 x 1170  Shipping Size: 725 x 770 x 1270	180 kg
---	--	--	--------

	<b>Maestro Mix B40C</b> <ul style="list-style-type: none"> <li>• 40 litre planetary mixer</li> <li>• 3 speed gearbox</li> <li>• Beater, whisk &amp; dough hook attachments</li> <li>• Lowering arm safety switch</li> <li>• Gear driven</li> <li>• Safety guard incorporating safety switch</li> <li>• External overload reset</li> <li>• 415volts, 3 phase + Neutral + Earth</li> </ul>	Unit Size: 620 x 600 x 1270  Shipping Size: 800 x 690 x 1400	248 kg
---	--	--	--------

Model	Product Description	Unit Size / Shipping Size W x D x H (mm)	Weight
-------	---------------------	---	--------

	<p><b>Maestro Mix B50C</b></p> <ul style="list-style-type: none"> <li>• 50 litre planetary mixer</li> <li>• 3 speed gearbox</li> <li>• Beater, whisk &amp; dough hook attachments</li> <li>• Lowering arm safety switch</li> <li>• Belt driven</li> <li>• Safety guard incorporating safety switch</li> <li>• External overload reset</li> <li>• 415volts, 3 phase + Neutral + Earth</li> </ul>	<p>Unit Size: 630 x 820 x 1220</p> <p>Shipping Size: 920 x 970 x 1440</p>	<p>282 kg</p>
---	---	---	---------------

 <p>New Model</p>	<p><b>Maestro Mix B60A</b></p> <ul style="list-style-type: none"> <li>• 60 litre planetary mixer</li> <li>• 3 speed gearbox</li> <li>• Beater, whisk &amp; dough hook attachments</li> <li>• Lowering arm safety switch</li> <li>• Missing bowl safety switch</li> <li>• Belt driven</li> <li>• Safety guard incorporating safety switch</li> <li>• External overload reset</li> <li>• 415volts, 3 phase + Neutral + Earth</li> </ul>	<p>Unit Size: 700 x 1000 x 1430</p> <p>Shipping Size: 790 x 1150 x 1640</p>	<p>460 kg</p>
---	---	---	---------------

	<p><b>Maestro Mix B80C</b></p> <ul style="list-style-type: none"> <li>• 80 litre planetary mixer</li> <li>• 4 speed gearbox with overdrive</li> <li>• Timer / Automatic function</li> <li>• Pulse control</li> <li>• Bowl trolley</li> <li>• Beater, whisk &amp; dough hook attachments</li> <li>• Lowering arm safety switch</li> <li>• Gear driven</li> <li>• Safety guard incorporating safety switch</li> <li>• External overload reset</li> <li>• 415volts, 3 phase + Neutral + Earth</li> </ul>	<p>Unit Size: 750 x 1050 x 1700</p> <p>Shipping Size: 860 x 1360 x 1800</p>	<p>720 kg</p>
---	---	---	---------------

Model	Product Description	Unit Size W x D x H (mm)	Weight
-------	---------------------	-----------------------------	--------

	Maestro Mix B10GFA	• Beater to suit Planetary Mixers	170 x 50 x 250	0.4 kg
	Maestro Mix B20GA		230 x 70 x 330	0.6 kg
	Maestro Mix B30C		300 x 80 x 380	1 kg
	Maestro Mix B40C		300 x 90 x 460	1.2 kg
	Maestro Mix B50C		300 x 90 x 460	1.2 kg
	Maestro Mix B60C		300 x 90 x 500	1.8 kg
	Maestro Mix B80C		300 x 90 x 500	1.8 kg

	Maestro Mix B10GFA	• Hook to suit Planetary Mixers	115 x 115 x 250	0.5 kg
	Maestro Mix B20GA		155 x 155 x 330	1 kg
	Maestro Mix B30C		195 x 195 x 380	2 kg
	Maestro Mix B40C		235 x 235 x 460	4 kg
	Maestro Mix B50C		275 x 275 x 460	3.5 kg
	Maestro Mix B60C		315 x 315 x 500	6.2 kg
	Maestro Mix B80C		355 x 355 x 500	5.5 kg

	Maestro Mix B10GFA	• Whisk to suit Planetary Mixers	150 x 150 x 250	0.6 kg
	Maestro Mix B20GA		220 x 220 x 330	1.3 kg
	Maestro Mix B30C		290 x 290 x 380	1.4 kg
	Maestro Mix B40C		360 x 360 x 460	3.2 kg
	Maestro Mix B50C		430 x 430 x 460	1.85 kg
	Maestro Mix B60C		500 x 500 x 500	3.9 kg
	Maestro Mix B80C		570 x 570 x 500	4.6 kg

	Maestro Mix B10GFA	• Bowl to suit Planetary Mixers	350 x 270 x 230	1.4 kg
	Maestro Mix B20GA		420 x 360 x 300	3.6 kg
	Maestro Mix B30C		510 x 390 x 370	6.5 kg
	Maestro Mix B40C		550 x 450 x 390	6.8 kg
	Maestro Mix B50C		510 x 440 x 440	7.1 kg
	Maestro Mix B60C		560 x 470 x 460	11.8 kg
	Maestro Mix B80C		650 x 540 x 470	13.8 kg

Model	Product Description	Unit Size / Shipping Size W x D x H (mm)	Weight
	<p><b>Maestro Mix LRM 10</b></p> <ul style="list-style-type: none"> <li>• 10 litre spiral mixer</li> <li>• Finished dough 8kg</li> <li>• Removable bowl</li> <li>• Chain driven</li> <li>• Quick release lift up head</li> <li>• Powder coated</li> <li>• Supplied with castors</li> <li>• Single speed</li> <li>• Safety guard incorporating safety switch</li> <li>• Safety switch to stop when there is no bowl</li> <li>• 240volts 10amps</li> </ul>	<p>Unit Size: 280 x 540 x 550</p> <p>Shipping Size: 390 x 720x 720</p>	<p>42 kg</p>
	<p><b>Maestro Mix LFM 25</b></p> <ul style="list-style-type: none"> <li>• 25 litre spiral mixer</li> <li>• Timer</li> <li>• Powder coated</li> <li>• Supplied with castors</li> <li>• Chain driven</li> <li>• Single speed</li> <li>• Safety guard incorporating safety switch</li> <li>• 240volts 10amps</li> </ul>	<p>Unit Size: 700 x 400 x 620</p> <p>Shipping Size: 780 x 480 x 760</p>	<p>87 kg</p>
	<p><b>Maestro Mix LFM 30</b></p> <ul style="list-style-type: none"> <li>• 30 litre spiral mixer</li> <li>• Timer</li> <li>• Powder coated</li> <li>• Supplied with castors</li> <li>• Chain driven</li> <li>• Single speed</li> <li>• Safety guard incorporating safety switch</li> <li>• 240volts 10amps</li> </ul>	<p>Unit Size: 820 x 450 x 720</p> <p>Shipping Size: 960 x 640 x 880</p>	<p>110 kg</p>
	<p><b>Maestro Mix LFM 50</b></p> <ul style="list-style-type: none"> <li>• 50 litre spiral mixer</li> <li>• Timer</li> <li>• Powder coated</li> <li>• Supplied with castors</li> <li>• Chain driven</li> <li>• Single speed</li> <li>• Safety guard incorporating safety switch</li> <li>• 240volts 10amps</li> </ul>	<p>Unit Size: 840 x 500 x 720</p> <p>Shipping Size: 960 x 640 x 880</p>	<p>125 kg</p>

Model	Product Description	Unit Size / Shipping Size W x D x H (mm)	Weight
-------	---------------------	---	--------

	<p><b>Maestro Mix RMJ-50</b></p>	<ul style="list-style-type: none"> <li>• 131 litre spiral mixer</li> <li>• Maximum 50kg flour</li> <li>• Computerized touchpad control panel, manual or automatic control available</li> <li>• Operation is simple and easy</li> <li>• Supplied with castors</li> <li>• Power 5.4Kw</li> <li>• 415volts, 3 phase + Neutral + Earth</li> </ul>	<p>Unit Size: 1110 x 710 x 1060</p>	<p>400 kg</p>
---	----------------------------------	---	---	---------------

	<p><b>Maestro Mix RMJ-75</b></p>	<ul style="list-style-type: none"> <li>• 187 litre spiral mixer</li> <li>• Maximum 75kg flour</li> <li>• Computerized touchpad control panel, manual or automatic control available</li> <li>• Operation is simple and easy</li> <li>• Supplied with castors</li> <li>• Power 8.4Kw</li> <li>• 415volts, 3 phase + Neutral + Earth</li> </ul>	<p>Unit Size: 1520 x 825 x 1365</p>	<p>600 kg</p>
--	----------------------------------	---	---	---------------

# Pastry Sheeter / Bun Divider

Model	Product Description	Unit Size / Shipping Size W x D x H (mm)	Weight
-------	---------------------	---	--------

	<p><b>Maestro Mix RMQ-520</b></p> <ul style="list-style-type: none"> <li>• 520mm wide floor standing pastry sheeter</li> <li>• S/steel cap at the ends of the belt</li> <li>• Guard in front of rollers</li> <li>• Emergency stop button</li> <li>• Foldable bench</li> <li>• 240volts 10amps</li> </ul>	<p>Unit Size: 2600 x 820 x 1150</p>	<p>150 kg</p>
---	--	---	---------------

	<p><b>Maestro Mix RMQ-620</b></p> <ul style="list-style-type: none"> <li>• 620mm wide floor standing pastry sheeter</li> <li>• S/steel cap at the ends of the belt</li> <li>• Guard in front of rollers</li> <li>• Emergency stop button</li> <li>• Foldable bench</li> <li>• 240volts 10amps</li> </ul>	<p>Unit Size: 2600 x 920 x 1150</p>	<p>180 kg</p>
--	--	---	---------------

	<p><b>Maestro Mix RMG-30</b></p> <ul style="list-style-type: none"> <li>• Bun Divider Moulder</li> <li>• Each dough produced 30 - 100 grams each</li> <li>• Includes 3 x plates</li> <li>• 415volts, 3 phase + Neutral + Earth</li> </ul>	<p>Unit Size: 640 X 540 X 2100</p>	<p>310 kg</p>
---	---	--	---------------

Model	Product Description	Unit Size / Shipping Size W x D x H (mm)	Weight
-------	---------------------	--	--------

	<p><b>Maestro Mix RMP-31</b></p>	<ul style="list-style-type: none"> <li>• Bench mounted bread slicer with 31 slices</li> <li>• 12mm blade distance / bread thickness per slice</li> <li>• Automatic touchable computer control panel</li> <li>• S/steel constructed</li> <li>• Easy to use</li> <li>• 240volts 10amps</li> </ul>	<p>Unit Size: 680 x 780 x 780</p> <p>Shipping Size: 780 x 880 x 880</p>	<p>80 kg</p>
---	----------------------------------	---	---	--------------

	<p><b>Maestro Mix RMP-39</b></p>	<ul style="list-style-type: none"> <li>• Bench mounted bread slicer with 39 slices</li> <li>• 10mm blade distance / bread thickness per slice</li> <li>• Automatic touchable computer control panel</li> <li>• S/steel constructed</li> <li>• Easy to use</li> <li>• 240volts 10amps</li> </ul>	<p>Unit Size: 780 x 780 x 780</p> <p>Shipping Size: 880 x 880 x 880</p>	<p>86 kg</p>
--	----------------------------------	---	---	--------------

	<p><b>Maestro Mix XF16-H</b></p>	<ul style="list-style-type: none"> <li>• Fermenting Proover</li> <li>• Holds 16 trays; 400 x 600</li> <li>• Produces 23kg per hour</li> <li>• Temperature range 20°C - 60°C</li> <li>• 240volts, 50Hz 10amps</li> </ul>	<p>Unit Size: 530 x 790 x 2050</p>	<p>124 kg</p>
---	----------------------------------	---	--	---------------

	<p><b>Maestro Mix XF32-H</b></p>	<ul style="list-style-type: none"> <li>• Fermenting Proover</li> <li>• Holds 32 trays; 400 x 600</li> <li>• Produces 46kg per hour</li> <li>• Temperature range 20°C - 60°C</li> <li>• 240volts, 50Hz 10amps</li> </ul>	<p>Unit Size: 1068 x 790 x 2050</p>	<p>175 kg</p>
---	----------------------------------	---	---	---------------



# Trolleys / Wire Mesh

Model	Product Description	Unit Size / Shipping Size W x D x H (mm)	Weight
-------	---------------------	---	--------

	<p><b>888 5 BASKET ANGLED</b></p>	<ul style="list-style-type: none"> <li>• 5 basket bread trolley angled</li> <li>• Chromed finish</li> <li>• On castors</li> </ul>		
---	---	---	--	--

	<p><b>888 6 BASKET HORIZ</b></p>	<ul style="list-style-type: none"> <li>• 6 basket bread trolley horizontal</li> <li>• Chromed finish</li> <li>• On castors</li> </ul>		
--	--	---	--	--

	<p><b>888 WIRE MESH 600 x 400</b></p> <p><b>730 x 405</b></p> <p><b>730 x 475</b></p>	<ul style="list-style-type: none"> <li>• Cooling wire mesh</li> <li>• 20mm square hole</li> <li>• Chrome plated</li> </ul>	<p>Unit Size:</p> <p>600 x 400</p> <p>730 x 405</p> <p>730 x 475</p>	
---	---	--	--	--

Model	Product Description	Unit Size / Shipping Size W x D x H (mm)	Weight
-------	---------------------	---	--------

	<p><b>Reef &amp; Beef RCG02</b></p>	<ul style="list-style-type: none"> <li>• BBQ 2 Burner</li> <li>• Available in Natural Gas or LPG</li> <li>• 36 Mj - 42,670 BTU</li> <li>• Basting rail included</li> <li>• Shelf under</li> </ul>	<p>Unit Size: 405 x 750 x 900</p>	
---	-------------------------------------	---	---------------------------------------	--

	<p><b>Reef &amp; Beef RCG04</b></p>	<ul style="list-style-type: none"> <li>• BBQ 4 Burner</li> <li>• Available in Natural Gas or LPG</li> <li>• 72 Mj - 85,300 BTU</li> <li>• Basting rail included</li> <li>• Shelf under</li> </ul>	<p>Unit Size: 680 x 750 x 900</p>	
--	-------------------------------------	---	---------------------------------------	--

 <p>Picture Only Does not include Hot Plate</p>	<p><b>Reef &amp; Beef RCG05</b></p>	<ul style="list-style-type: none"> <li>• BBQ 5 Burner</li> <li>• Available in Natural Gas or LPG</li> <li>• 90 Mj - 85,370 BTU</li> <li>• Basting rail included</li> <li>• Shelf under</li> </ul>	<p>Unit Size: 860 x 750 x 900</p>	
--	-------------------------------------	---	---------------------------------------	--

	<p><b>Reef &amp; Beef RCG07</b></p>	<ul style="list-style-type: none"> <li>• BBQ 7 Burner</li> <li>• Available in Natural Gas or LPG</li> <li>• 135 Mj - 127,980 BTU</li> <li>• Basting rail included</li> <li>• Shelf under</li> </ul>	<p>Unit Size: 1200 x 750 x 900</p>	
---	-------------------------------------	---	--	--

# BBQ Burner

Model	Product Description	Unit Size / Shipping Size W x D x H (mm)	Weight
-------	---------------------	---	--------

	<p><b>Reef &amp; Beef RCG09</b></p>	<ul style="list-style-type: none"> <li>• BBQ 9 Burner</li> <li>• Available in Natural Gas or LPG</li> <li>• 174 Mj - 164,952 BTU</li> <li>• Basting rail included</li> <li>• Shelf under</li> </ul>	<p>Unit Size: 1500 x 750 x 900</p>	
---	---	---	--	--

	<p><b>Reef &amp; Beef RCG HOT PLATE</b></p>	<ul style="list-style-type: none"> <li>• Hot plate</li> <li>• 450 x 463</li> <li>• Covers 3 burners</li> </ul>	<p>Unit Size: 450 x 463</p>	<p>12 kg</p>
--	---	--	---------------------------------	--------------

# WOK888 Waterless Cooling Woks

**2008 AWARD  
WINNING  
WATERLESS WOK**

Model	Product Description	Unit Size / Shipping Size W x D x H (mm)	Weight
-------	---------------------	--	--------

	<p><b>WOK888 Single Hole Wok</b></p> <p><b>1B CH WL</b></p>	<ul style="list-style-type: none"> <li>• S/steel single hole wok</li> <li>• Waterless cooling</li> <li>• Available in duckbill or chimney burner</li> <li>• Available in Natural Gas or LPG</li> <li>• Knee operated water control for wok pan rinsing</li> <li>• Food catcher as well as a drainer</li> <li>• Very energy efficient</li> <li>• Legs, rings and shelf are removable for compact transport</li> <li>• Suitable to fit through any doorway</li> <li>• Italian gas controls and pilots</li> <li>• 100 Mj</li> </ul>	<p>Unit Size: 600 x 900 x 1300</p> <p>Shipping Size: 450 x 700 x 800</p>	60 kg
---	---	--	--	-------

	<p><b>WOK888 Two Hole Wok</b></p> <p><b>2B CH WL</b></p>	<ul style="list-style-type: none"> <li>• S/steel two hole wok</li> <li>• Waterless cooling</li> <li>• Available in duckbill or chimney burner</li> <li>• Available in Natural Gas or LPG</li> <li>• Knee operated water control for wok pan rinsing</li> <li>• Food catcher as well as a drainer</li> <li>• Very energy efficient</li> <li>• Legs, rings and shelf are removable for compact transport</li> <li>• Suitable to fit through any doorway</li> <li>• Italian gas controls and pilots</li> <li>• 200 Mj</li> </ul>	<p>Unit Size: 1200 x 900 x 1300</p> <p>Shipping Size: 650 x 700 x 800</p>	90 kg
--	--	---	---	-------

 <p>A combination of a double and single wok</p>	<p><b>WOK888 Three Hole Wok</b></p> <p><b>3B CH WL</b></p>	<ul style="list-style-type: none"> <li>• S/steel three hole wok</li> <li>• Waterless cooling</li> <li>• Available in duckbill or chimney burner</li> <li>• Available in Natural Gas or LPG</li> <li>• Knee operated water control for wok pan rinsing</li> <li>• Food catcher as well as a drainer</li> <li>• Very energy efficient</li> <li>• Legs, rings and shelf are removable for compact transport</li> <li>• Suitable to fit through any doorway</li> <li>• Italian gas controls and pilots</li> <li>• 300 Mj</li> </ul>	<p>Unit Size: 1800 x 900 x 1300</p> <p>Shipping Size: 1100 x 700 x 800</p>	150 kg
---	--	---	--	--------

	<p><b>WOK888 Low Boiling Table</b></p> <p><b>1LOWDB</b></p>	<ul style="list-style-type: none"> <li>• Single boiling table incorporating duckbill burner for fast heating</li> <li>• Waterless cooling</li> <li>• Available in Natural Gas or LPG</li> <li>• Legs, rings and shelf are removable for compact transport</li> <li>• 100 Mj</li> <li>• Suitable to fit through any doorway</li> </ul>	<p>Unit Size: 600 x 850 x 1245</p> <p>Shipping Size: 450 x 700 x 800</p>	60 kg
---	---	---	--	-------

NOTE: Please specify whether it's a Chimney or Duckbill Burner  
Please specify Natural Gas or LPG

# ROYSTON Rotisserie

Model	Product Description	Unit Size / Shipping Size W x D x H (mm)	Weight
-------	---------------------	---	--------

	<b>ROYSTON 4BIVR</b>	<ul style="list-style-type: none"> <li>• 4 Burner Infrared Vertical Rotisserie</li> <li>• Available in Natural Gas or LPG</li> <li>• Flame failure incorporating thermo electric burner safety cut out</li> <li>• Bench mounted</li> <li>• Rotate clockwise or anti-clockwise</li> <li>• Adjustable radiant head, moves forward and backwards to control heat</li> <li>• 10amps for skewer rotation motor</li> <li>• 240volts 10amps</li> <li>• 64Mj</li> </ul>	Unit Size: 563 x 708 x 1027  Shipping Size: 610 x 758 x 1077	100 kg
---	----------------------	---	--	--------

## Grill Top

Model	Product Description	Unit Size / Shipping Size W x D x H (mm)	Weight
-------	---------------------	---	--------

	<b>ROYSTON WG-500D</b>	<ul style="list-style-type: none"> <li>• Electric grill</li> <li>• Cooking area 500mm wide</li> <li>• Temperature range 50°C to 350°C</li> <li>• 240volts 10amps, 50Hz</li> </ul>	Unit Size: 500 x 520 x 310  Shipping Size: 510 x 530 x 320	30 kg
---	------------------------	---	--	-------

	<b>ROYSTON ETK-D1</b>	<ul style="list-style-type: none"> <li>• Electric satay grill</li> <li>• Energy saver</li> <li>• High efficiency</li> <li>• S/steel finish</li> <li>• 240volts 15amps</li> </ul>	Unit Size: 780 x 310 x 170  Shipping Size: 830 x 360 x 220	
---	-----------------------	--	--	--

# Fornetto Deck Ovens

Model	Product Description	Unit Size / Shipping Size W x D x H (mm)	Weight
-------	---------------------	--	--------

	<b>FORNETTO YCD-2D1</b>	<ul style="list-style-type: none"> <li>• Electric single deck oven with stone base</li> <li>• Includes 2 trays</li> <li>• S/Steel constructed</li> <li>• Power 7Kw</li> <li>• 415volts, 3 phase + Neutral + Earth</li> </ul>	Unit Size: 1210 x 810 x 520	140 kg
---	-------------------------	--	--------------------------------	--------

	<b>FORNETTO YCD-2-4D1</b>	<ul style="list-style-type: none"> <li>• Electric two deck oven with stone base</li> <li>• Include 4 trays</li> <li>• S/Steel constructed</li> <li>• Include stand on castors: 1210W x 810D x 400H</li> <li>• Power 15.5Kw</li> <li>• 415volts, 3 phase + Neutral + Earth</li> </ul>	Unit Size: 1210 x 810 x 1280	245 kg
--	---------------------------	--	---------------------------------	--------

	<b>FORNETTO YCD-3-6D1</b>	<ul style="list-style-type: none"> <li>• Electric three deck oven with stone base</li> <li>• Include 6 trays</li> <li>• S/Steel constructed</li> <li>• On castors</li> <li>• Power 23Kw</li> <li>• 415volts, 3 phase + Neutral + Earth</li> </ul>	Unit Size: 1210 x 810 x 1485	425 kg
---	---------------------------	---	---------------------------------	--------

	<b>FORNETTO YCD-3-9D1</b>	<ul style="list-style-type: none"> <li>• Electric three deck oven with stone base</li> <li>• Include 9 trays</li> <li>• S/Steel constructed</li> <li>• On castors</li> <li>• Power 30.6Kw</li> <li>• 415volts, 3 phase + Neutral + Earth</li> </ul>	Unit Size: 1610 x 810 x 1485	430 kg
---	---------------------------	---	---------------------------------	--------

# Fornetto Deck Ovens

Model	Product Description	Unit Size / Shipping Size W x D x H (mm)	Weight
-------	---------------------	--	--------

 <p>IMAGE NOT AVAILABLE</p>	<p><b>FORNETTO RMC-3D</b></p>	<ul style="list-style-type: none"> <li>• Electric three deck oven</li> <li>• Steam generator</li> <li>• Chamber size: 1500 x 880 x 200</li> <li>• Total cooking area inside chamber: 880D x 1500W x 200H</li> <li>• Power 57.5Kw</li> <li>• 415volts, 3 phase + Neutral + Earth</li> </ul>	<p>Unit Size: 1920 x 1180 x 1800</p>	<p>425 kg</p>
--	-------------------------------	--	--	---------------

	<p><b>FORNETTO STONE ONLY</b></p>	<ul style="list-style-type: none"> <li>• Single stone <u>only</u> to suit FORNETTO deck ovens</li> <li>• Per stone: 430mm x 630mm x 18mm</li> </ul>	<p>Unit Size: 430 x 630 x 18</p>	
--	-----------------------------------	---	--------------------------------------	--





	<p><b>FORNETTO TRAYS TO SUIT</b></p>	<ul style="list-style-type: none"> <li>• Trays to suit FORNETTO deck ovens</li> <li>• Tray size: 400 x 600</li> </ul>		
---	--------------------------------------	---	--	--

	<p><b>FORNETTO STAND TO SUIT</b></p>	<ul style="list-style-type: none"> <li>• Metal stand on castors</li> <li>• To suit FORNETTO deck ovens</li> </ul>		
---	--------------------------------------	---	--	--

# *Fornetto* **Spare Parts for Ovens**

	Model	Product Description
<b>ELECTRICAL PARTS</b> <b>FOR FIRST MODEL BYDFL</b>	TOP ELEM BYDFL 12/24	Top element to suit BYDFL 12/24
	BTM ELEM BYDFL 12/24	Bottom element to suit BYDFL 12/24
	CNTCTR BYDFL 12/24	Contactator to suit BYDFL 12/24
	FUSE BYDFL 12/24	Fuse to suit BYDFL 12/24
	O/TEMP CTRL BYDFL 12/24	Over temp to suit BYDFL 12/24

# ROYSTON Convection Ovens / Toaster

Model	Product Description	Unit Size / Shipping Size W x D x H (mm)	Weight
	<p><b>ROYSTON CV-261</b></p> <ul style="list-style-type: none"> <li>• Convection Oven</li> <li>• Double galzed door</li> <li>• Internal light</li> <li>• Temperature adjusted 0°C - 300°C</li> <li>• 120min timer</li> <li>• S/steel construction</li> <li>• 240volts, 15amps</li> </ul>	<p>Unit Size: 780 x 600 x 570</p> <p>Shipping Size: 830 x 650 x 620</p>	<p>48 kg</p>
	<p><b>ROYSTON CV-262S</b></p> <ul style="list-style-type: none"> <li>• Convection Oven</li> <li>• Steam generator</li> <li>• Double galzed door</li> <li>• Internal light</li> <li>• S/steel construction</li> <li>• 240volts, 10amps</li> </ul>	<p>Unit Size: 600 x 550 x 580</p> <p>Shipping Size: 830 x 50 x 620</p>	<p>32 kg</p>
	<p><b>ROYSTON DH6A-A</b></p> <ul style="list-style-type: none"> <li>• Convection Oven</li> <li>• Capacity fits 6 x (400 x 600) trays</li> <li>• S/steel construction</li> <li>• Automatic reversing fan</li> <li>• Twin glass</li> <li>• Bakes and steams</li> <li>• Temperature can be adjusted from 20°C to 300°C</li> <li>• Automatic thermostat</li> <li>• 1 to 99 minute timer</li> <li>• Spray function for different kinds of baking requirement</li> <li>• 415volts, 3 phase + Neutral + Earth</li> </ul>	<p>Unit Size: 1000 x 875 x 810</p>	<p>120 kg</p>
	<p><b>ROYSTON MHQ-360</b></p> <ul style="list-style-type: none"> <li>• Electric toaster</li> <li>• 240volts 10amps</li> </ul>	<p>Unit Size: 590 x 350 x 465</p>	<p>9 kg</p>

Model	Product Description	Unit Size / Shipping Size W x D x H (mm)	Weight
-------	---------------------	---	--------





	<p><b>888 CD01</b></p>	<ul style="list-style-type: none"> <li>• Chip dump</li> <li>• Heated element on the bottom</li> <li>• Cupboard for storing oil filter</li> <li>• Heat lamp above</li> <li>• 10amp</li> </ul>	<p>Unit Size: 500 x 760 x 1430</p> <p>Shipping Size: 550 x 800 x 1400</p>	<p>45 kg</p>
---	----------------------------	--	---	--------------

	<p><b>888 MK2</b></p>	<ul style="list-style-type: none"> <li>• Chip dump</li> <li>• Thermostat controlled</li> <li>• Heated element on the bottom</li> <li>• Oil filter storage and shelf above</li> <li>• Heat lamp above</li> <li>• Chip dump can be made to be on the left hand side or the right hand side</li> <li>• 10amp</li> </ul>	<p>Unit Size: 1400 x 750 x 1380</p> <p>Shipping Size: 1450 x 800 x 1450</p>	<p>45 kg</p>
--	---------------------------	--	---	--------------





	<p><b>ROYSTON IS6602</b></p>	<ul style="list-style-type: none"> <li>• Angled glass pie warmer</li> <li>• 3 tray display</li> <li>• Internal light</li> <li>• Humidity tray included</li> <li>• 10amps</li> </ul>	<p>Unit Size: 780 x 600 x 570</p> <p>Shipping Size: 830 x 650 x 620</p>	<p>48 kg</p>
---	----------------------------------	---	---	--------------

	<p><b>ROYSTON DH-1P</b></p>	<ul style="list-style-type: none"> <li>• Heated display cabinet</li> <li>• 4 sided glass</li> <li>• Display's 3 shelves</li> <li>• Adjustable temperature</li> <li>• 240volts 10amps</li> </ul>	<p>Unit Size: 350 x 425 x 500</p>	<p>16 kg</p>
---	---------------------------------	---	---------------------------------------	--------------

# ROYSTON Food Warming

Model	Product Description	Unit Size / Shipping Size W x D x H (mm)	Weight
	<p><b>ROYSTON DH-580</b></p> <ul style="list-style-type: none"> <li>• Pie warmer</li> <li>• Holds 50 pies</li> <li>• Glasses with heat resistance</li> <li>• 240volts 10amps</li> </ul>	<p>Unit Size: 640 x 360 x 530</p>	<p>21 kg</p>
	<p><b>ROYSTON DH-805</b></p> <ul style="list-style-type: none"> <li>• Pie Warmer</li> <li>• Holds 100 pies</li> <li>• Glasses with heat resistance</li> <li>• 240volts 10amps</li> </ul>	<p>Unit Size: 865 x 360 x 625</p>	<p>35 kg</p>
	<p><b>ROYSTON MME-500H</b></p> <ul style="list-style-type: none"> <li>• Heavy duty food display steamer</li> <li>• Fully s/steel</li> <li>• Can be used as a steamer or a warmer</li> <li>• Ideal for steaming buns and dim sims</li> <li>• 240volts 10amps</li> </ul>	<p>Unit Size: 380 x 400 x 745</p>	<p>22 kg</p>
	<p><b>ROYSTON SB-6000</b></p> <ul style="list-style-type: none"> <li>• Soup Kettle</li> <li>• 10 litre</li> <li>• Ladle hole</li> <li>• Easy cleaning</li> <li>• Outer casing without heat transfer</li> <li>• 10amps</li> </ul>	<p>Unit Size: 345Diam x 360High</p>	<p>4.5 kg</p>

# ROYSTON Bench Top Fryers

Model	Product Description	Unit Size / Shipping Size W x D x H (mm)	Weight
	<p><b>ROYSTON ET-ZL1</b></p> <ul style="list-style-type: none"> <li>• 5 litre single tank bench top fryer</li> <li>• Element guard</li> <li>• Supplied with 1 basket</li> <li>• Safety temperature cut out with reset</li> <li>• Easily removable tank</li> <li>• S/steel construction</li> <li>• Thermostat controlled</li> <li>• Heavy duty insulated handles</li> <li>• Reaches temperature quickly with fast recovery</li> <li>• Single phase 10amps</li> </ul>	<p>Unit Size: 285 x 440 x 305</p> <p>Shipping Size: 480 x 330 x 300</p>	<p>5 kg</p>
	<p><b>ROYSTON ET-ZL2</b></p> <ul style="list-style-type: none"> <li>• 2 x 5 litre double tank bench top fryer</li> <li>• Element guard</li> <li>• Supplied with 2 basket</li> <li>• Safety temperature cut out with reset</li> <li>• Easily removable tank</li> <li>• S/steel construction</li> <li>• Thermostat controlled</li> <li>• Heavy duty insulated handles</li> <li>• Reaches temperature quickly with fast recovery</li> <li>• Single phase, 10amps</li> </ul>	<p>Unit Size: 580 x 440 x 310</p> <p>Shipping Size: 600 x 500 x 330</p>	<p>10 kg</p>
	<p><b>ROYSTON ET-BASKET</b></p> <ul style="list-style-type: none"> <li>• Basket fryer</li> <li>• To suit ET-ZL1 and ET-ZL2</li> <li>• Insulated handles</li> </ul>	<p>Unit Size: 190 x 440 x 125</p> <p>Shipping Size: 200 x 280 x 290</p>	<p>1.08 kg</p>
	<p><b>ROYSTON JS-6L-2</b></p> <ul style="list-style-type: none"> <li>• Electric bench top double tank fryer</li> <li>• Supplied with 2 basket</li> <li>• High efficient heating</li> <li>• Temperature control</li> <li>• S/steel construction</li> <li>• 15amps</li> </ul>	<p>Unit Size: 580 x 470 x 300</p> <p>Shipping Size: 630 x 520 x 350</p>	<p>12 kg</p>

# ROYSTON Vegetable Preparation



Model	Product Description	Unit Size / Shipping Size W x D x H (mm)	Weight
-------	---------------------	---	--------

	<p><b>ROYSTON HLC300</b></p>	<ul style="list-style-type: none"> <li>• Vegetable preparation machine</li> <li>• Powerful 550 watt motor</li> <li>• Continuous feed for high output</li> <li>• Cast aluminium body</li> <li>• Integrated safety cut out switches</li> <li>• Disks compatible with other brands</li> <li>• Include 5 blades, 3 slicers and 2 graters</li> <li>• 240volts 10amps</li> </ul>	<p>Unit Size: 400 x 290 x 540</p> <p>Shipping Size: 560 x 290 x 560</p> <p>25 kg</p>
---	------------------------------	--	--

	<p><b>ROYSTON DICING CUTTER KIT</b></p>	<ul style="list-style-type: none"> <li>• Dicing cutter kit</li> <li>• To suit HLC300</li> </ul>	
--	---	---	--

# ROYSTON Meat Slicer

COUNTERLINE / FOOD PREP

Model	Product Description	Unit Size / Shipping Size W x D x H (mm)	Weight
	<b>ROYSTON HBS250</b> <ul style="list-style-type: none"> <li>• Meat slicer with 250mm blade (10")</li> <li>• Tough hand guard</li> <li>• Built-in sharpener</li> <li>• Micrometric thickness control adjustment</li> <li>• Smooth glide</li> <li>• Belt driven</li> <li>• Easy to clean</li> <li>• Excellent for luncheon meats, roasts, small and large cold cuts</li> <li>• Safety switch on plate cover</li> <li>• 240volts 10amps</li> </ul>	Unit Size: 280 x 460 x 340  Shipping Size: 293 x 465 x 355	20 kg
	<b>ROYSTON ES-300</b> <ul style="list-style-type: none"> <li>• Meat slicer with 300mm blade (12")</li> <li>• Tough hand guard</li> <li>• Built-in sharpener</li> <li>• Micrometric thickness control adjustment</li> <li>• Smooth glide</li> <li>• Belt driven</li> <li>• Easy to clean</li> <li>• Excellent for luncheon meats, roasts, small and large cold cuts</li> <li>• Safety switch on plate cover</li> <li>• 240volts 10amps</li> </ul>	Unit Size: 330 x 510 x 400  Shipping Size: 343 x 515 x 415	28 kg
	<b>ROYSTON SL-300B</b> <ul style="list-style-type: none"> <li>• Automatic meat slicer</li> <li>• Choice of manual or automatic mode</li> <li>• Blade made out of #304 s/steel</li> <li>• Blade diameter 300mm</li> <li>• Thickness of slicing meat can be adjusted from 0 to 15mm</li> <li>• Easy to use</li> <li>• 240volts 10amps</li> </ul>	Unit Size: 640 x 600 x 750  Shipping Size: 730 x 670 x 840	68 kg

# ROYSTON Meat Mincer

Model	Product Description	Unit Size / Shipping Size W x D x H (mm)	Weight
-------	---------------------	---	--------

	<b>ROYSTON TC12</b> <ul style="list-style-type: none"> <li>• Heavy duty meat mincer</li> <li>• S/steel construction</li> <li>• 120kg per hour</li> <li>• Forward and reverse function</li> <li>• Overload protection</li> <li>• 240V 50Hz</li> <li>• 10amps</li> </ul>	Unit Size: 230 x 420 x 540  Shipping Size: 250 x 470 x 590	30.5 kg
---	--	--	---------

	<b>ROYSTON TC22</b> <ul style="list-style-type: none"> <li>• Heavy duty meat mincer</li> <li>• S/steel construction</li> <li>• 220kg per hour</li> <li>• Forward and reverse function</li> <li>• Overload protection</li> <li>• 240V 50Hz</li> <li>• 10amps</li> </ul>	Unit Size: 240 x 460 x 580  Shipping Size: 290 x 510 x 630	36 kg
--	--	--	-------

	<b>ROYSTON TC32</b> <ul style="list-style-type: none"> <li>• Heavy duty meat mincer</li> <li>• S/steel construction</li> <li>• 320kg per hour</li> <li>• Forward and reverse function</li> <li>• Overload protection</li> <li>• 240V 50Hz</li> <li>• 10amps</li> </ul>	Unit Size: 250 x 480 x 600  Shipping Size: 330 x 550 x 610	
---	--	--	--

# ROYSTON Sausage Fillers

Model	Product Description	Unit Size / Shipping Size W x D x H (mm)	Weight
-------	---------------------	--	--------

	<b>ROYSTON TV3</b> <ul style="list-style-type: none"> <li>• Vertical sausage filler</li> <li>• 3kg capacity</li> <li>• Manual operation</li> <li>• S/steel construction</li> </ul>	Unit Size: 540 x 310 x 270	11 kg
---	--	-------------------------------	-------

	<b>ROYSTON TV5</b> <ul style="list-style-type: none"> <li>• Vertical sausage filler</li> <li>• 5kg capacity</li> <li>• Manual operation</li> <li>• S/steel construction</li> </ul>	Unit Size: 660 x 310 x 270	12 kg
--	--	-------------------------------	-------

	<b>ROYSTON TV10</b> <ul style="list-style-type: none"> <li>• Vertical sausage filler</li> <li>• 10kg capacity</li> <li>• Manual operation</li> <li>• S/steel construction</li> </ul>	Unit Size: 420 x 315 x 620	
---	--	-------------------------------	--

	<b>ROYSTON TV15</b> <ul style="list-style-type: none"> <li>• Vertical sausage filler</li> <li>• 15kg capacity</li> <li>• Manual operation</li> <li>• S/steel construction</li> </ul>	Unit Size: 420 x 315 x 750	
---	--	-------------------------------	--



# ROYSTON Pasta Machine

Model	Product Description	Unit Size / Shipping Size W x D x H (mm)	Weight
-------	---------------------	---	--------

	<p><b>ROYSTON 150F</b></p> <ul style="list-style-type: none"> <li>• Manual pasta machine</li> <li>• Capable of producing: <ul style="list-style-type: none"> <li>- Spaghetti</li> <li>- Lasagne</li> <li>- Fettuccine</li> <li>- Tagliatelle</li> </ul> </li> </ul>	<p>Unit Size: 210 x 210 x 160</p> <p>Shipping Size: 210 x 160 x 140</p>	<p>3.6 kg</p>
---	---	---	---------------

	<p><b>ROYSTON MS-9</b></p> <ul style="list-style-type: none"> <li>• Multi functional pasta machine</li> <li>• 9kg per hour capacity</li> <li>• Benchtop</li> <li>• Dies include macaroni, shell, fettuccine, angel hair, thick noodle / spaghetti</li> <li>• Easy to clean</li> <li>• 415volts 3 phase + Neutral + Earth</li> </ul>	<p>Unit Size: 600 x 330 x 430</p> <p>Shipping Size: 740 x 410 x 530</p>	<p>60 kg</p>
--	---	---	--------------

	<p><b>ROYSTON MS-25</b></p> <ul style="list-style-type: none"> <li>• Multi functional pasta machine</li> <li>• 25kg per hour capacity</li> <li>• Free standing</li> <li>• Dies include macaroni, shell, fettucini, angel hair, thick noodle / spaghetti</li> <li>• Easy to clean</li> </ul>	<p>Unit Size: 460 x 960 x 1155</p> <p>Shipping Size: 460 x 960 x 1160</p>	<p>250 kg</p>
---	---	---	---------------

# ROYSTON Pizza Accessories

Model	Product Description	Unit Size / Shipping Size W x D x H (mm)	Weight
-------	---------------------	---	--------

	<p><b>ROYSTON PBG3</b></p>	<ul style="list-style-type: none"> <li>• Stain resistant</li> <li>• Heavy duty carry straps</li> <li>• Velcro strips faster loading and unloading</li> <li>• Rack included</li> <li>• Easy to clean</li> <li>• Receipt pouch</li> <li>• Insulated</li> </ul>	<p>Unit Size: 420 x 450 x 450</p>	<p>3 kg</p>
---	----------------------------	--	---------------------------------------	-------------



	<p><b>ROYSTON PIZZA RACKS</b></p>	<ul style="list-style-type: none"> <li>• Pizza base holder</li> <li>• Chromed steel</li> <li>• Holds 18 pizza trays</li> <li>• Can be bench or wall mounted</li> </ul>	<p>Unit Size: 370 x 330 x 980</p>	<p>3.5 kg</p>
--	-----------------------------------	--	---------------------------------------	---------------

# ROYSTON Juicer & Blender

Model	Product Description	Unit Size / Shipping Size W x D x H (mm)	Weight
-------	---------------------	---	--------

	<p><b>ROYSTON A2000</b></p> <ul style="list-style-type: none"> <li>• Centrifugal juicer</li> <li>• Bench mounted with 90mm pulp ejection chute</li> <li>• High juice production</li> <li>• 6 different spout position</li> <li>• Heavy duty</li> <li>• Unique grater design for high yield</li> <li>• Professional juicer continuous use</li> <li>• 240volts 10amps</li> </ul>	<p>Unit Size: 460 x 310 x 500</p> <p>Shipping Size: 490 x 360 x 530</p>	<p>24 kg</p>
---	--	---	--------------

	<p><b>ROYSTON TM800A</b></p> <ul style="list-style-type: none"> <li>• Multi-function blender</li> <li>• 1.5 litre jug capacity</li> <li>• Wet and dry application</li> <li>• Crushes ice in seconds</li> <li>• Two in one s/steel cutting blade</li> <li>• Industrial high speed motor</li> <li>• Light weight, stackable, premium quality, transparent polycarbonate jug</li> <li>• 10amps</li> </ul>	<p>Unit Size: 235 x 213 x 405</p> <p>Shipping Size: 240 x 220 x 410</p>	<p>8 kg</p>
--	--	---	-------------

  	<p><b>ROYSTON 756A JAR COMPLETE</b></p> <ul style="list-style-type: none"> <li>• Polycarb jug complete with blades and lid</li> <li>• Stackable</li> </ul> <p><b>756A JAR (JUG ONLY)</b></p> <ul style="list-style-type: none"> <li>• Polycarb jug with blade</li> <li>• Stackable</li> </ul> <p><b>756A JAR (LID ONLY)</b></p> <ul style="list-style-type: none"> <li>• Jug lid only</li> </ul>	<p>Unit Size: 190 x 190 x 230</p> <p>190 x 190 x 225</p> <p>160 x 160 x 25</p>	
---	--	--	--

# ROYSTON Ice Machines

Model	Product Description	Unit Size / Shipping Size W x D x H (mm)	Weight
-------	---------------------	---	--------

	<b>ROYSTON ZB-10</b> <ul style="list-style-type: none"> <li>• Bench top ice maker</li> <li>• 10kg capacity every 24 hours</li> <li>• Bullet ice</li> <li>• No plumbing required</li> <li>• 240volts 10amps</li> </ul>	Unit Size: 305 x 380 x 380  Shipping Size: 400 x 465 x 510	20 kg
---	---	--	-------

	<b>ROYSTON ET-200</b> <ul style="list-style-type: none"> <li>• Bench top ice shaver</li> <li>• Hand operated</li> <li>• Easy to operate</li> <li>• 240volts 10amps</li> </ul>	Unit Size: 390 x 240 x 340  Shipping Size: 440 x 290 x 390	8.5 kg
--	---	--	--------

# Upright Refrigerators

Model	Product Description	Unit Size / Shipping Size W x D x H (mm)	Weight
-------	---------------------	---	--------

	<p><b>MITCHEL GN650TN</b></p>	<ul style="list-style-type: none"> <li>• 650 litre single door refrigerator</li> <li>• Fully s/steel interior and exterior</li> <li>• Temperature range 0°C to +10°C</li> <li>• Adjustable shelves</li> <li>• Frost free</li> <li>• LED display</li> <li>• On castors</li> <li>• Fan cooled</li> <li>• 240volts, 50Hz, 10amps</li> </ul>	<p>Unit Size: 740 x 830 x 2075</p> <p>Shipping Size: 770 x 890 x 2055</p> <p>117 kg</p>
---	-------------------------------	--	---

	<p><b>MITCHEL D1000L4FR</b></p>	<ul style="list-style-type: none"> <li>• 1000 litre 4 door refrigerator</li> <li>• Fully s/steel interior and exterior</li> <li>• Temperature range 0°C to +10°C</li> <li>• Adjustable shelves</li> <li>• Frost free</li> <li>• LED display</li> <li>• On castors</li> <li>• Fan cooled</li> <li>• 240volts, 50Hz, 10amps</li> </ul>	<p>Unit Size: 1200 x 760 x 1945</p> <p>Shipping Size: 1250 x 810 x 1945</p> <p>158 kg</p>
--	---------------------------------	--	---

	<p><b>MITCHEL D1200L4FR</b></p>	<ul style="list-style-type: none"> <li>• 1200 litre 4 door refrigerators</li> <li>• Fully s/steel interior and exterior</li> <li>• Temperature range 0°C to +10°C</li> <li>• Adjustable shelves</li> <li>• Frost free</li> <li>• LED display</li> <li>• On castors</li> <li>• Fan cooled</li> <li>• 240volts, 50Hz, 10amps</li> </ul>	<p>Unit Size: 1500 x 760 x 1945</p> <p>Shipping Size: 1550 x 810 x 1945</p> <p>180 kg</p>
---	---------------------------------	---	---

	<p><b>MITCHEL D1600L6FR</b></p>	<ul style="list-style-type: none"> <li>• 1600 litre 6 door refrigerators</li> <li>• Fully s/steel interior and exterior</li> <li>• Temperature range 0°C to +10°C</li> <li>• Adjustable shelves</li> <li>• Frost free</li> <li>• LED display</li> <li>• On castors</li> <li>• Fan cooled</li> <li>• 240volts, 50Hz, 10amps</li> </ul>	<p>Unit Size: 1820 x 760 x 1945</p> <p>Shipping Size: 1870 x 810 x 1945</p> <p>217 kg</p>
---	---------------------------------	---	---

# Upright Freezers

	Model	Product Description	Unit Size / Shipping Size W x D x H (mm)	Weight
	<b>MITCHEL GN650BT</b>	<ul style="list-style-type: none"> <li>• 650 litre single door freezer</li> <li>• Fully s/steel interior and exterior</li> <li>• Temperature range -18°C to -20°C</li> <li>• Adjustable shelves</li> <li>• Frost free</li> <li>• LED display</li> <li>• On castors</li> <li>• Fan cooled</li> <li>• 240volts, 50Hz, 10amps</li> </ul>	Unit Size: 740 x 830 x 2015  Shipping Size: 770 x 890 x 2055	117 kg
	<b>MITCHEL CFD-2FF</b>	<ul style="list-style-type: none"> <li>• 1321 litre 2 solid door freezer</li> <li>• Fully s/steel interior and exterior</li> <li>• Temperature range -18°C ~ -22°C</li> <li>• Fits GN 1/1 pans</li> <li>• Ventilated cooling system</li> <li>• Frost free</li> <li>• LED display</li> <li>• On castors</li> <li>• Self closing doors</li> <li>• Adjustable shelves</li> <li>• Security door lock</li> <li>• Low mounted compressor</li> <li>• 240volts 10amps</li> </ul>	Unit Size: 736 x 818 x 2095  Shipping Size: 786 x 868 x 2145	203 kg
	<b>MITCHEL D1200L4F</b>	<ul style="list-style-type: none"> <li>• 1200 litre 4 door freezer</li> <li>• Fully s/steel interior and exterior</li> <li>• Temperature -22°C</li> <li>• Adjustable shelves</li> <li>• Frost free</li> <li>• LED display</li> <li>• On castors</li> <li>• Fan cooled</li> <li>• 240volts, 50Hz, 10amps</li> </ul>	Unit Size: 1200 x 760 x 1945  Shipping Size: 1250 x 810 x 1945	180 kg



# Upright Glass Doors

Model	Product Description	Unit Size / Shipping Size W x D x H (mm)	Weight
-------	---------------------	---	--------

	<p><b>MITCHEL LG-1000M2/W</b></p>	<ul style="list-style-type: none"> <li>• 1000 litre 2 glass door drink fridge</li> <li>• Temperature range 0°C to +10°C</li> <li>• LED display, digital temperature control</li> <li>• Standard light box</li> <li>• Self closing doors</li> <li>• Security door lock</li> <li>• Contains 5 shelves per door (split)</li> <li>• Bottom mounted refrigeration</li> <li>• Frost free</li> <li>• On castors</li> <li>• 240volts 10amps</li> </ul>	<p>Unit Size: 1220 x 640 x 2080</p> <p>Shipping Size: 1330 x 780 x 2235</p>	<p>155 kg</p>
---	---------------------------------------	--	---	---------------

	<p><b>MITCHEL D768BM2F</b></p>	<ul style="list-style-type: none"> <li>• 708 litre 2 glass door freezer</li> <li>• Temperature range -15°C ~ -18°C</li> <li>• Ventilated cooling system</li> <li>• Frost free</li> <li>• LED display</li> <li>• On castors</li> <li>• Self closing doors</li> <li>• Contains 4 shelves per door (split)</li> <li>• 240volts 10amps</li> </ul>	<p>Unit Size: 1250 x 660 x 2040</p> <p>Shipping Size: 1300 x 710 x 2090</p>	<p>180 kg</p>
--	------------------------------------	---	---	---------------

# Undercounter Bars

	Model	Product Description	Unit Size / Shipping Size W x D x H (mm)	Weight
	<b>MITCHEL TG15L2A</b>	<ul style="list-style-type: none"> <li>• 336 litre 2 solid door undercounter refrigerator</li> <li>• Fully s/steel interior and exterior</li> <li>• Electronic thermostat</li> <li>• Ventilated cooling system</li> <li>• Frost free</li> <li>• Temperature range 0°C ~ 10°C</li> <li>• Self closing swing doors</li> <li>• Adjustable shelves</li> <li>• 240volts 10amps</li> </ul>	Unit Size: 1480 x 700 x 850  Shipping Size: 1530 x 750 x 900	112 kg
	<b>MITCHEL TG19L3A</b>	<ul style="list-style-type: none"> <li>• 509 litre 3 solid door undercounter refrigerator</li> <li>• Fully s/steel interior and exterior</li> <li>• Electronic thermostat</li> <li>• Ventilated cooling system</li> <li>• Frost free</li> <li>• Temperature range 0°C ~ 10°C</li> <li>• Self closing swing doors</li> <li>• Adjustable shelves</li> <li>• 240volts 10amps</li> </ul>	Unit Size: 1955 x 700 x 850  Shipping Size: 1005 x 750 x 900	137 kg

# Preparation Bars

	Model	Product Description	Unit Size / Shipping Size W x D x H (mm)	Weight
	<b>MITCHEL PICL3</b>	<ul style="list-style-type: none"> <li>• Pizza preparation bar with 3 doors</li> <li>• 684 litre capacity</li> <li>• Fully s/steel interior and exterior</li> <li>• Ventilated cooling system</li> <li>• Frost free</li> <li>• Temperature range 0°C ~ 10°C</li> <li>• Self closing swing doors</li> <li>• Adjustable shelves</li> <li>• Rear mounted motor</li> <li>• 240volts 10amps</li> </ul>	Unit Size: 2334 x 800 x 1088  Shipping Size: 2384 x 850 x 1138	200 kg

# Preparation Bars

Model	Product Description	Unit Size / Shipping Size W x D x H (mm)	Weight
-------	---------------------	--	--------

	<p><b>MITCHEL SCL2</b></p> <ul style="list-style-type: none"> <li>• Sandwich preparation bar with 2 doors</li> <li>• 268 litre capacity</li> <li>• Suits 1/2 G/N tray</li> <li>• Fully s/steel interior and exterior</li> <li>• Ventilated cooling system</li> <li>• Frost free</li> <li>• Temperature range 0°C ~ 10°C</li> <li>• Self closing swing doors</li> <li>• Adjustable shelves</li> <li>• Rear mounted motor</li> <li>• 240volts 10amps</li> </ul>	<p>Unit Size: 1188 x 750 x 1075</p> <p>Shipping Size: 1238 x 800 x 1125</p>	<p>115 kg</p>
---	---	---	---------------

	<p><b>MITCHEL SCL3</b></p> <ul style="list-style-type: none"> <li>• Sandwich preparation bar with 3 doors</li> <li>• 440 litre capacity</li> <li>• Suits 1/2 G/N tray</li> <li>• Fully s/steel interior and exterior</li> <li>• Ventilated cooling system</li> <li>• Frost free</li> <li>• Temperature range 0°C ~ 10°C</li> <li>• Self closing swing doors</li> <li>• Adjustable shelves</li> <li>• Rear mounted motor</li> <li>• 240volts 10amps</li> </ul>	<p>Unit Size: 1787 x 750 x 1075</p> <p>Shipping Size: 1837 x 800 x 1125</p>	<p>156 kg</p>
--	---	---	---------------

	<p><b>MITCHEL SCLM2</b></p> <ul style="list-style-type: none"> <li>• Noodle/juice preparation bar with 2 doors</li> <li>• 268 litre capacity</li> <li>• Suits 1/1 G/N tray</li> <li>• Fully s/steel interior and exterior</li> <li>• Ventilated cooling system</li> <li>• Frost free</li> <li>• Temperature range 0°C ~ 10°C</li> <li>• Self closing swing doors</li> <li>• Adjustable shelves</li> <li>• Rear mounted motor</li> <li>• 240volts 10amps</li> </ul>	<p>Unit Size: 1188 x 864 x 1166</p> <p>Shipping Size: 1238 x 800 x 1125</p>	<p>135 kg</p>
---	--	---	---------------

	<p><b>MITCHEL SCLM3</b></p> <ul style="list-style-type: none"> <li>• Noodle/juice preparation bar with 3 doors</li> <li>• 440 litre capacity</li> <li>• Suits 1/1 G/N tray</li> <li>• Fully s/steel interior and exterior</li> <li>• Ventilated cooling system</li> <li>• Frost free</li> <li>• Temperature range 0°C ~ 10°C</li> <li>• Self closing swing doors</li> <li>• Adjustable shelves</li> <li>• Rear mounted motor</li> <li>• 240volts 10amps</li> </ul>	<p>Unit Size: 1787 x 864 x 1166</p> <p>Shipping Size: 1837 x 800 x 1125</p>	<p>188 kg</p>
---	--	---	---------------

# Flat Top Chest Freezers

Model	Product Description	Unit Size / Shipping Size W x D x H (mm)	Weight
-------	---------------------	---	--------

	<b>MITCHEL BD-200</b>	<ul style="list-style-type: none"> <li>• 200 litre flat top chest freezer</li> <li>• Colour bond</li> <li>• Temperature control knob</li> <li>• High performance</li> <li>• On castors</li> <li>• Low power consumption</li> <li>• Supplied with 1 baskets</li> <li>• 240volts 10amps</li> </ul>	Unit Size: 920 x 545 x 810  Shipping Size: 970 x 595 x 860	40 kg
---	---------------------------	--	--	-------

	<b>MITCHEL BD-300</b>	<ul style="list-style-type: none"> <li>• 300 litre flat top chest freezer</li> <li>• Colour bond</li> <li>• Temperature control knob</li> <li>• High performance</li> <li>• On castors</li> <li>• Low power consumption</li> <li>• Supplied with 1 baskets</li> <li>• 240volts 10amps</li> </ul>	Unit Size: 1100 x 625 x 810  Shipping Size: 1150 x 675 x 860	48 kg
--	---------------------------	--	--	-------

	<b>MITCHEL BD-550</b>	<ul style="list-style-type: none"> <li>• 550 litre flat top chest freezer</li> <li>• Colour bond</li> <li>• Temperature control knob</li> <li>• High performance</li> <li>• On castors</li> <li>• Low power consumption</li> <li>• Supplied with 2 baskets</li> <li>• 240volts 10amps</li> </ul>	Unit Size: 1545 x 740 x 960  Shipping Size: 1595 x 790 x 1010	82 kg
---	---------------------------	--	---	-------

	<b>MITCHEL BD-600</b>	<ul style="list-style-type: none"> <li>• 600 litre flat top chest freezer</li> <li>• Colour bond</li> <li>• Temperature control knob</li> <li>• High performance</li> <li>• On castors</li> <li>• Low power consumption</li> <li>• Supplied with 2 baskets</li> <li>• 240volts 10amps</li> </ul>	Unit Size: 1715 x 740 x 960  Shipping Size: 1765 x 790 x 1010	87 kg
---	---------------------------	--	---	-------



# Glass Top Chest Freezers

Model	Product Description	Unit Size / Shipping Size W x D x H (mm)	Weight
-------	---------------------	---	--------

	<p><b>MITCHEL WD-200</b></p>	<ul style="list-style-type: none"> <li>• 200 litre push and pull glass door chest freezer</li> <li>• Colour bond</li> <li>• Temperature control knob</li> <li>• High performance</li> <li>• On castors</li> <li>• Supplied with 3 baskets</li> <li>• 240volts 10amps</li> </ul>	<p>Unit Size: 1050 x 550 x 880</p> <p>Shipping Size: 1100 x 600 x 930</p> <p>52 kg</p>
---	----------------------------------	---	--

	<p><b>MITCHEL WD-300</b></p>	<ul style="list-style-type: none"> <li>• 300 litre push and pull glass door chest freezer</li> <li>• Colour bond</li> <li>• Temperature control knob</li> <li>• High performance</li> <li>• On castors</li> <li>• Supplied with 4 baskets</li> <li>• 240volts 10amps</li> </ul>	<p>Unit Size: 1375 x 635 x 880</p> <p>Shipping Size: 1425 x 685 x 930</p> <p>68 kg</p>
--	----------------------------------	---	--

# Display Cabinets

Model	Product Description	Unit Size / Shipping Size W x D x H (mm)	Weight	
	<b>MITCHEL SC900</b>	<ul style="list-style-type: none"> <li>• 900mm straight glass warming cabinet</li> <li>• Triple glazed front glass</li> <li>• ON / OFF switch for front light panel</li> <li>• Temperature range:</li> <li>• 240volts 10amps</li> </ul>	Unit Size: 1060 x 860 x 1400  Shipping Size: 1110 x 910 x 1450	60 kg
	<b>MITCHEL SC1200AT3</b>	<ul style="list-style-type: none"> <li>• 1200mm straight glass cold cake display</li> <li>• Triple glazed and heated front glass</li> <li>• ON / OFF switch for front light panel</li> <li>• Temperature range: 2°C to 8°C</li> <li>• 240volts 10amps</li> </ul>	Unit Size: 1300 x 860 x 1400  Shipping Size: 1350 x 910 x 1450	110 kg
	<b>MITCHEL SC1500AT3</b>	<ul style="list-style-type: none"> <li>• 1500mm straight glass cold cake display</li> <li>• Triple glazed and heated front glass</li> <li>• ON / OFF switch for front light panel</li> <li>• Temperature range: 2°C to 8°C</li> <li>• 240volts 10amps</li> </ul>	Unit Size: 1600 x 860 x 1400  Shipping Size: 1650 x 910 x 1450	120 kg



# ACCOUNT APPLICATION FORM

www.888foodequipment.com.au

## 888 Importing Pty Ltd

ABN: 86 547 310 979  
56 Tarnard Drive, Braeside VIC 3195, Australia  
Phone / Fax: +613 9543 1175

**PLEASE INDICATE IF ACCOUNT IS IN NAME OF:**  
INDIVIDUAL      COMPANY      BUSINESS

### PARTNERSHIP / BUSINESS / COMPANY INFORMATION

PARTNERSHIP / BUSINESS OR

COMPANY NAME: \_\_\_\_\_ ABN NUMBER: \_\_\_\_\_  
TRADING NAME: \_\_\_\_\_ ACN NUMBER: \_\_\_\_\_  
DATE COMMENCED TRADE: \_\_\_\_\_ DATE OF INCORPORATION: \_\_\_\_\_  
POSTAL ADDRESS: \_\_\_\_\_  
DELIVERY ADDRESS: \_\_\_\_\_  
PHONE: \_\_\_\_\_ FAX: \_\_\_\_\_

DIRECTORS / INDIVIDUAL NAME: \_\_\_\_\_ NAME: \_\_\_\_\_  
ADDRESS: \_\_\_\_\_ ADDRESS: \_\_\_\_\_  
PHONE No.: \_\_\_\_\_ PHONE No.: \_\_\_\_\_  
DATE OF BIRTH: \_\_\_\_\_ DATE OF BIRTH: \_\_\_\_\_  
DRIVERS LICENCE No.: \_\_\_\_\_ DRIVERS LICENCE No.: \_\_\_\_\_

### \*MUST FILL IN - TRADE REFERENCES AND ADDITIONAL INFORMATION

NAME: \_\_\_\_\_ ADDRESS: \_\_\_\_\_ FAX: \_\_\_\_\_  
NAME: \_\_\_\_\_ ADDRESS: \_\_\_\_\_ FAX: \_\_\_\_\_  
NAME: \_\_\_\_\_ ADDRESS: \_\_\_\_\_ FAX: \_\_\_\_\_  
NAME: \_\_\_\_\_ ADDRESS: \_\_\_\_\_ FAX: \_\_\_\_\_

AMOUNT OF CREDIT SOUGHT: \$ \_\_\_\_\_

### TRANSPORT DETAILS:

COMPANY NAME: \_\_\_\_\_ ACCOUNT No.: \_\_\_\_\_

### BANKING DETAILS:

NAME OF BANK: \_\_\_\_\_ BRANCH: \_\_\_\_\_  
OVERDRAFT LIMIT: \_\_\_\_\_ ANY REGISTERED CHARGES: \_\_\_\_\_

### PERSONAL GUARANTEE GUARANTEE & INDEMNITY

In consideration of 888 Food Equipment (hereinafter call "The Company") supplying goods and or services for the price upon terms and conditions agreed upon the applicant organization applying above credit (herein after called "The Purchaser") DO HEREBY CONVENANT for myself and my executors, administrators and successors as the case may be with the said Company that if at anytime default shall be made in payment of any money owing by the said Purchaser to the said Company for the purchase of goods and services i will forthwith on demand by the said Company pay the whole or any such part of the price as shall then be due and payable to the said Company. This guarantee shall be a continuing guarantee and shall not be released by any neglect or forbearance on the part of the said Company in enforcing or by any extension of time given to the said Purchaser for payment of the purchase price payable or by any act or thing which under the law relating to sureties which would but for this provision have the effect of releasing myself and my executors, administrators and successors, the singular shall include the plural.

I / We undertake to advise of any change of Ownership / Directorship and agree to the trading terms listed on this form and the attached terms and conditions of sale.

DATED THIS DAY: \_\_\_\_\_ OF THIS MONTH: \_\_\_\_\_ OF 20 \_\_\_\_\_

SIGNED BY THE SAID: \_\_\_\_\_ SIGNED BY THE SAID: \_\_\_\_\_

PRINT NAME: \_\_\_\_\_ PRINT NAME: \_\_\_\_\_

DATE: \_\_\_\_\_ DATE: \_\_\_\_\_

IN THE PRESENCE OF; PRINT NAME: \_\_\_\_\_ IN THE PRESENCE OF; PRINT NAME: \_\_\_\_\_

SIGN: \_\_\_\_\_ DATE: \_\_\_\_\_ SIGN: \_\_\_\_\_ DATE: \_\_\_\_\_



# TERMS AND CONDITIONS

## TERMS OF TRADE

### ACCOUNTS - STRICTLY 7 DAYS / 30 DAYS FROM DATE OF INVOICE

In consideration of application for 7/30 credit being approved, I/We declare and agree to the following.

I/We undertake to settle all accounts within 7 days / 30 days from date of invoice and immediately notify you of any change in details of particulars set out in this application. I clearly understand that the breach of this undertaking will involve the withdrawal of the 7 day / 30 day credit facility with 888 Importing Pty Ltd to C.O.D immediate issue of legal process for recovery of any outstanding accounts.

Agree to pay and legal costs resulting from any action to recover any outstanding accounts owing to me and or my company. No goods will be ordered unless the company has the capacity to pay the invoiced prices.

Will notify 888 Importing Pty Ltd promptly of any proposed change to the company / business. Upon and constitutional change to the company / business notification will be given in writing immediately, and until notification is given, I/We agree to accept liability as if no change has taken place.

## GOVERNING LAW

This account shall be governed by and operated in accordance with the law of the State of Victoria and the parties submit to the jurisdiction of the Victorian Courts.

## OWNERSHIP AND DELIVERY OF GOODS

Legal and beneficial ownership of any goods delivered to the Purchaser will only be transferred to the purchaser.

When the purchaser has met all moneys owing to the vendor on whatever basis. Until payment in full by the purchaser to the Vendor, the purchaser is required to store the goods hereby sold in such a way that they are seperated from other property of the purchaser and are clearly identified as property of the vendor, until payment in full to the vendor of all moneys the purchaser owes to the vendor, the purchaser will keep the goods sold as bailee for tge vendor but may sell the goods to a thrid party in ordinary course of business and deliver them. In that event, any debt arising from the sale of the goods or any goods in which third party will be held by the purchaser or trust for the vendor in a seperate account until the purchaser has paid the vendor all money which the purchaser owes to the vendor.

The account when past due the Terms of Trade specified above shall also be charged with interest at the rate of interest as appropriate and set out under section 2 of the penalty Interest Act of 1983.

I have read, and understand, and agree to the terms and conditions set above;

SIGNED BY THE SAID: \_\_\_\_\_

SIGNED BY THE SAID: \_\_\_\_\_

PRINT NAME: \_\_\_\_\_

PRINT NAME: \_\_\_\_\_

DATE: \_\_\_\_\_

DATE: \_\_\_\_\_

IN THE PRESENCE OF;  
PRINT NAME: \_\_\_\_\_

IN THE PRESENCE OF;  
PRINT NAME: \_\_\_\_\_

SIGN: \_\_\_\_\_ DATE: \_\_\_\_\_

SIGN: \_\_\_\_\_ DATE: \_\_\_\_\_

DATE RECIEVED: \_\_\_\_\_

CREDIT LIMIT: \$ \_\_\_\_\_

AUTHORISED BY: \_\_\_\_\_

ACCOUNT No.: \_\_\_\_\_

APPROVED / REJECTED BY: \_\_\_\_\_

TERMS: \_\_\_\_\_ DAYS: \_\_\_\_\_

COMMENTS: \_\_\_\_\_  
\_\_\_\_\_  
\_\_\_\_\_  
\_\_\_\_\_



# CONDITIONS OF SALE

## 1. GENERAL:

- 1.1 Within these conditions the following definitions apply;
- (a) "The Company" means 888 IMPORTING Pty Ltd
  - (b) "The Goods" means any components or equipment manufactured or sold by the company.
  - (c) "The Distributor" means the person or entity purchasing the goods from the "Company".

## 2. APPROVED CREDIT:

- 2.1 Credit is extended solely at the discretion of the Company and may be withdrawn without notice temporarily or for an extended period at the discretion of the Company.

## 3. TERMS: (NON ACCOUNT ONLY)

- 3.1 All goods must be fully paid by clear funds prior to pick up or delivery. NO EXCEPTIONS.

## 4. TERMS OF PAYMENT: (ACCOUNTS ONLY)

- 4.1 Approved accounts will accept strictly nett 30 day settlement from the day of the invoice of purchase.
- 4.2 Outstanding accounts in excess of 30 days settlement will incur interest charges at the companies ruling overdraft rate at the discretion of the Company.
- 4.3 Non-approved accounts will be strictly pre-paid prior to delivery.
- 4.4 Payment made by cheque will not be deemed to be made until and unless the relevant cheque is cleared.
- 4.5 In the event that payment is not received in clear funds by Company due date the Company may in its discretion;
- (a) Immediately cease any extension of credit.
  - (b) Immediately at its own discretion without attracting any liability withhold delivery of all other goods for Distributor orders that have received and accepted by the.
  - (c) Charge the Distributor interest on overdue amounts at a rate of 14% per annum on a daily basis.
  - (d) Charge to the Distributor all administration and other cost as incurred by the Company in relation to the collection of outstanding amounts owed by the Distributor to the Supplier.
- 4.6 Prices quoted are ex the Companies premises unless otherwise stated in Delivery, Freight Charges and Freight Insurance.

## 5. CREDIT CARD PAYMENTS:

- 5.1 The company does not accept offline voucher credit card transactions as approved voucher signatures are required on all credit card transactions.
- 5.2 Fees apply to all credit card transactions.

## 6. RETENTION OF TITLE:

- 6.1 The goods supplied with this invoice ('goods') remain the property of 888 IMPORTING Pty Ltd ("Company") until the company has received all amounts due to it in respect of the goods in the form of clear funds.
- 6.2 Risk in the goods passes to the distributor on delivery and the distributor indemnifies and will keep indemnified the company against loss or damage to the goods, however caused, occurring after delivery.
- 6.3 If the distributor fails to make any payment due to the company, the distributor must at its cost return the goods to the company on the request and at the direction of the company.
- 6.4 These provisions are without prejudice to any common law or statutory rights available to the company. While the company retains title to the goods, the purchaser must not sell, pledge, mortgage, lend, transfer, encumber or otherwise deal the goods without the prior written consent of the company.
- 6.5 On the occurrence of any breach of this invoice the company is irrevocably authorized at any time to enter any premises where the goods are situated and to take possession of and remove the goods.
- 6.6 All legal litigation necessary to recover the cost of goods and or other company costs shall be carried out in the state of Victoria.

## 7. LIABILITY & GENERAL CONDITIONS:

- 7.1 The Company will prepare and pack goods for shipment with due care but will not be responsible for loss or damage to goods shipped by the Distributors agent whether nominated by the Company or by the Distributor. The company will not be held responsible for any damage caused to property during deliveries, such as floors, tiles, door frames, cabinets, walls, benches etc. The company arranges freight on customer's behalf. The company is not liable for damages incurred during transport or for transport delays.
- 7.2 The price given does not include any building alterations, plumbing, electrical or installation work of any kind. All working areas at point of delivery are to be cleared and power supply available at time of installation and delivery.
- 7.3 Extra work or time wasted due to non-fulfillment of above conditions will be charged at the prevailing hourly rate. The distributor shall insure all equipment against loss of stock due to equipment breakdown.

## 8. NO LIABILITY:

- 8.1 The Supplier accepts no liability for goods supplied by a third party who has not purchased the goods directly from the supplier.

## 9. CREDITS:

- 9.1 Claims for credit must be supported with the Company invoice or receipt and ensure that no goods have been used, and are in the exact condition as supplied. Such claims will not be recognized after 7 days from the date of delivery or pick up and will only apply to goods incorrectly supplied by the Company.

## 10. RETURNS & REFUNDS:

- 10.1 30% re-stocking fee for returned, unused stock items within 7 days applies to all standard goods.
- 10.2 Used or damaged goods will not be returnable.
- 10.3 Special orders, custom goods and non-standard items cannot be returned or refunded.
- 10.4 The company reserves the right to deny refunds on any purchases and apply an in-store credit.

## 11. WARRANTY:

- 11.1 Goods supplied by the Company are subject to a 12 month warranty covering faulty manufacture commencing from the Company's invoice date for purchase.
- 11.2 Faulty manufacture of goods supplied shall only be determined by the Company's authorized personnel.
- 11.3 The warranty constitutes no charge or repair or replacement of faulty components ex factory.
- 11.4 The Company accepts no responsibility for misuse or wrong application of goods supplied, and will not be covered under warranty in these circumstances.
- 11.5 This warranty does not cover light bulbs, thermocouples, dirty evaporators causing motor fusion, glass and elements. The End User / Distributor must not perform remedial work to alleged defective Goods with out first obtaining the written permission of the Company to do so.
- 11.6 The End User / Distributor's failure to provide written notice to the Company with in the required time of any alleged breach of the warranty will release and discharge the Company from any obligation or liability for that breach of warranty.
- 11.7 Warranty work is to be performed during normal business working hours – Monday to Friday (9.00am to 5.00pm), except Saturday, Sunday and public holidays and does not include travel to and from the goods location. Delivery to and from the Company or its service agents is the responsibility of the Distributor as the Company accepts no responsibility for poor care of equipment during transit.

## 12. ORDERS:

- 12.1 Orders must be placed by purchase order issued by the distributor. Any order from the Distributor for the supply of goods shall not be binding on the Company until accepted by the Company.
- 12.2 Orders must be accompanied by the necessary ordering information including model numbers, item numbers or part numbers.
- 12.3 The Distributor may withdraw or cancel any order prior to acceptance from the Company, where discretion of the Company cancellation is otherwise acceded to the distributor shall pay the Company an amount equivalent to twenty percent of the agreed price of the goods by way of liquidated charges. Order of non-stock items may not be cancelled under any circumstances

## 13. Consignment Stock:

- 13.1 If the Company supplies Goods on a Consignment basis then the following shall apply:
- (a) The Distributor will bear all risk of loss and/or damage to the Consignment Goods and must in addition, effect and maintain insurance against loss, fire and theft of the consignment Goods in an amount adequate to cover the Company interest as owner of such Consignment Goods.
  - (b) The Distributor must keep the Consignment Goods free from liens, encumbrances and adverse claims of all kinds which otherwise might diminish or adversely affect the Company exercise of its full rights of ownership of the Consignment Goods.
  - (c) If the Consignment Good are lost or damaged while in the distributors care, the Distributor undertakes to reimburse the Company within 30 days of the date of replacement or repair, as the case maybe, the full cost of such replacement or repair. The same also applies to any manuals, cartons and accessories that are supplied as standard with the Consignment Goods.
  - (d) The Distributor must provide upon request to the Company within 5 days a complete list of all Consignment Goods held by the Distributor. The Company also bears the right to invoice immediately any Consignment Goods that are no longer held and confirmed by the Distributor.

## 14. PRICES:

- 14.1 The prices printed are suggested list prices only subject to various trade discounts and GST or other ruling charges where applicable.
- 14.2 Prices quoted are ex-Company factory and are subject to change without notice.
- 14.3 All prices & specifications listed on the company website, internet or printed promotions are subject to change without notice

## 15. SPECIFICATIONS:

- 15.1 The Company reserves the right to alter specifications without notice including print, web site and other company literature.

## 16. DELIVERY, FREIGHT CHARGES & FREIGHT INSURANCE:

- 16.1 Freight charges apply when delivery of goods is required, and can be arranged if paid for in clear funds prior to dispatch.
- 16.2 Freight insurance must be specified by the Distributor at the time of order at an additional charge. Please note we are not common carriers.
- 16.3 The Distributor is not liable for any claims for the non fulfillment of late delivery of goods of for any loss or damage (including consequential loss or damage) arising from delay in delivery or a failure to deliver. The Distributor shall accept and pay for the Goods notwithstanding delivery.
- 16.4 The Distributor is entitled to deliver Goods, to the Distributor in one or more lots. Where delivery of the goods is effected by way of part delivery, the Supplier shall be entitled to invoice the Distributor for pro rata progress payments in respect thereof.

## 17. DEPOSITS:

- 17.1 Deposits with order: Custom goods 50% - Standard Goods 20%.
- 17.2 Deposits for custom goods will not be refunded under any circumstances. Deposits for standard goods will not be refunded if goods are not fully paid for 90 days from the time of order.

## 18. STORAGE:

- 18.1 Storage of paid goods will be done at the discretion of the company, and storage costs may apply.

## 19. DISPUTES

- 19.1 Any disputes between the parties arising from the performance of the provisions of these Conditions of Sale not resolved through friendly consultation by the parties within 30 days will be finally settled in the court system of Victoria

All legal litigation necessary to recover the costs of goods and or other company cost shall be carried out in the state of Victoria.



**888 Importing Pty Ltd**  
**Victoria - Australia**  
**Website: [www.888foodequipment.com.au](http://www.888foodequipment.com.au)**  
**Email: [sales@888foodequipment.com.au](mailto:sales@888foodequipment.com.au)**  
**Phone/Fax: 03 9543 1175      Mobile: 0418 332 771**